

# INSTALLATION INSTRUCTIONS

## **EGR ROLLTRAC**

### ELECTRIC

**Vehicle Model: FORD RANGER - PX (Europe/UK)**  
**Year of manufacture: 2011 onwards**

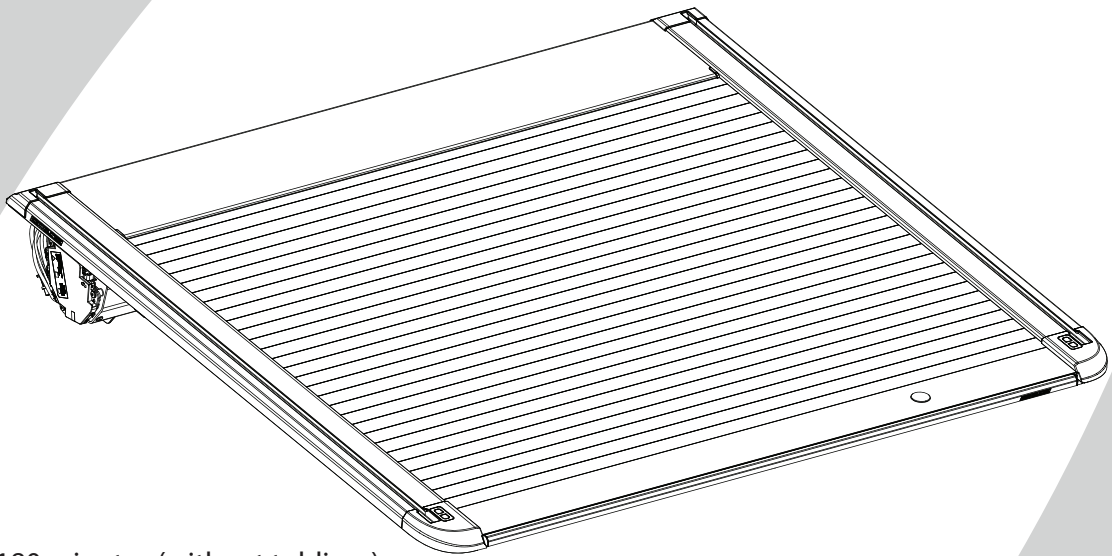

Installation time: 180 minutes (without tubliner)

#### Caution

- Do not attach EGR RollTrac in a location or by a method not specified.
- Do not use this product for any vehicle make or model, other than those specified in this document.
- Do not remove the plaque or label from this product.
- Do not modify the structure of the EGR RollTrac in any way.

#### General Notes

- Read through the fitting instructions before installation of EGR RollTrac.
- Always install the accessory following the fitting instructions. Failure to do so may cause damage to the vehicle or the accessory.
- Ensure all recyclable discarded vehicle accessory components and packaging are recycled following local recycling regulations.
- It is always recommended that this accessory is fitted by a qualified Technician.
- Safely store and protect any removed vehicle components.
- Ensure all bare metal surfaces are protected using Automotive Bare Metal Primer and touch-up paint.
- Remove all metal swarf and dust from all vehicle surfaces if surface is used for accessory installation.



#### Safety Notes

- Check that all work practices comply with safety standards.
- Please wear appropriate clothing and use safety equipment.



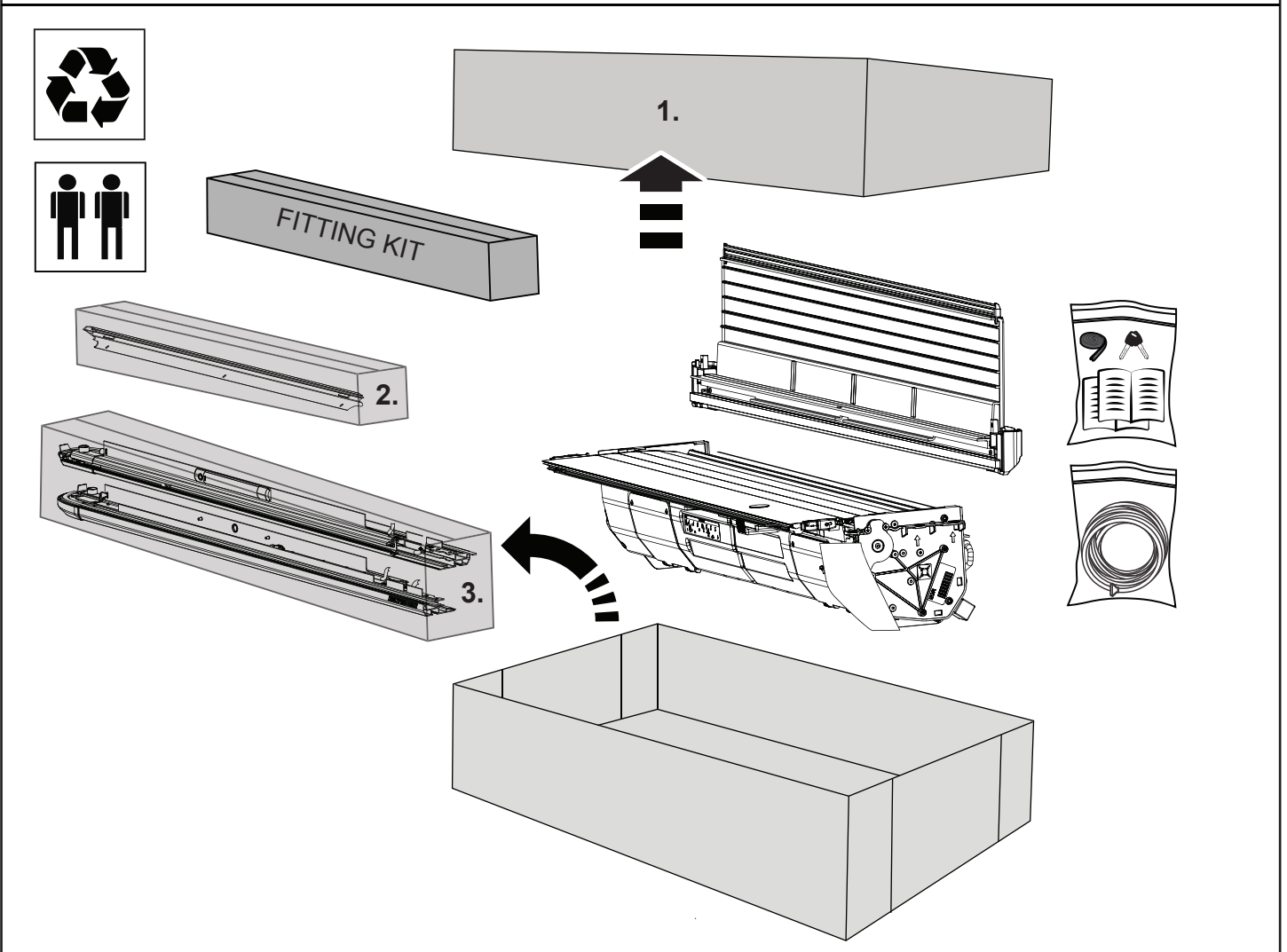
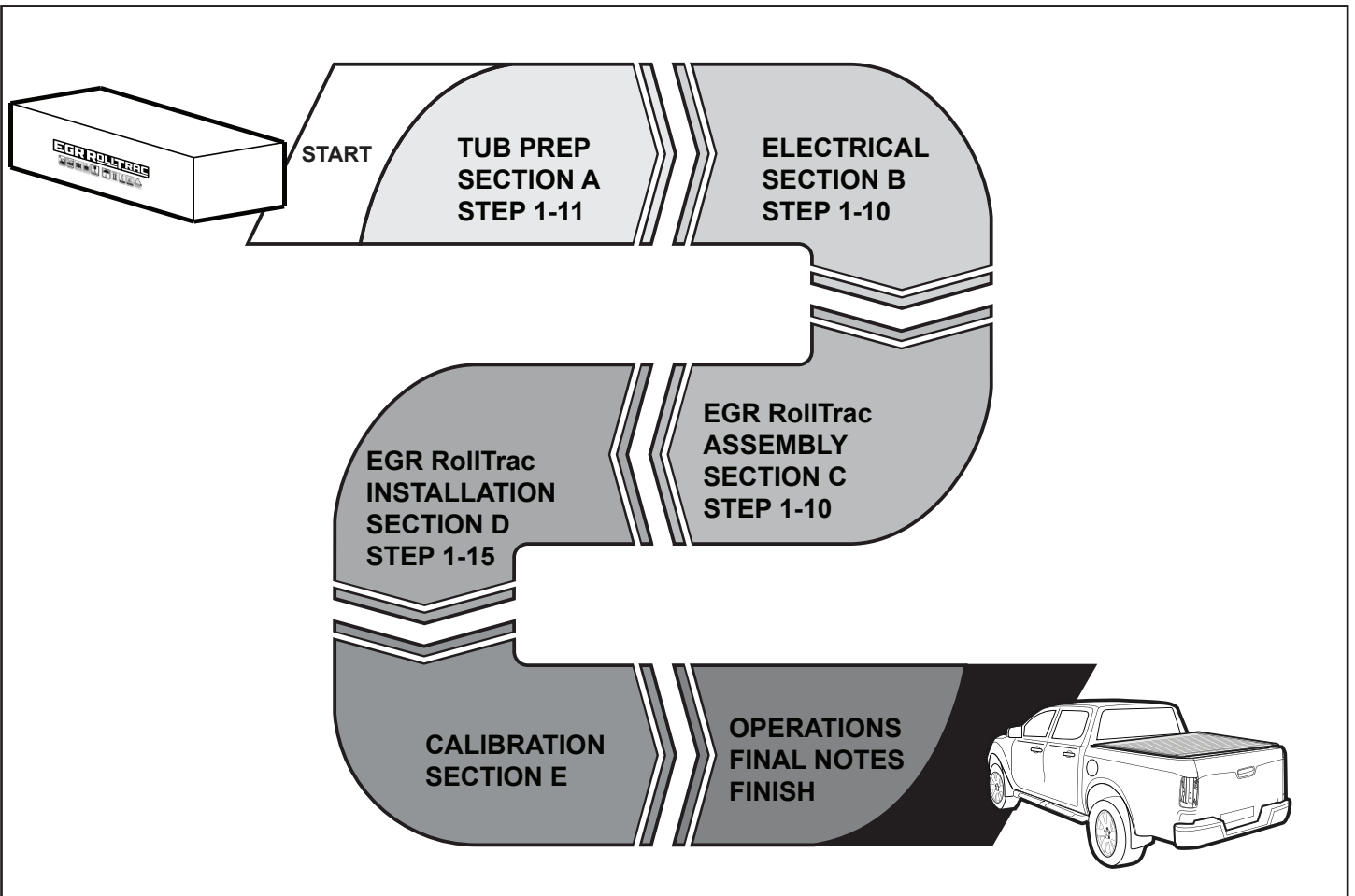

## KIT CONTENTS - COMPONENT NUMBER AND QUANTITY

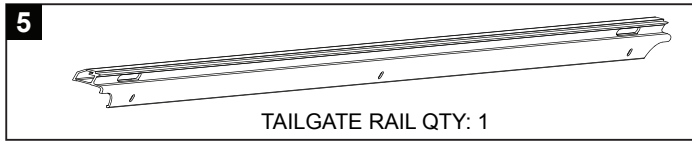
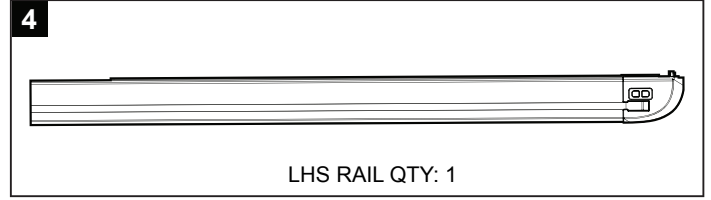
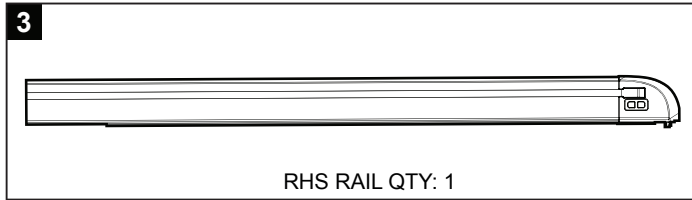
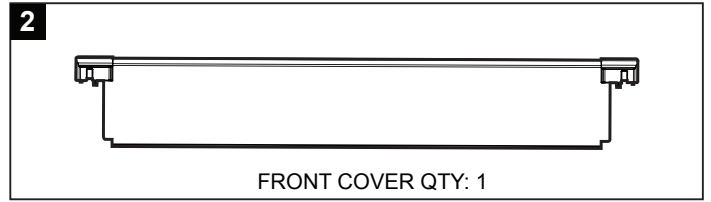
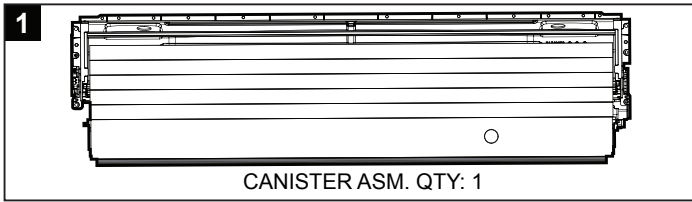



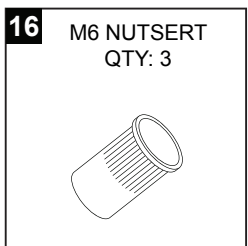
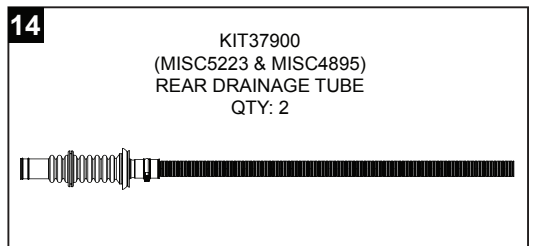
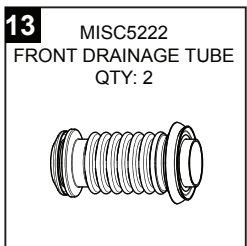
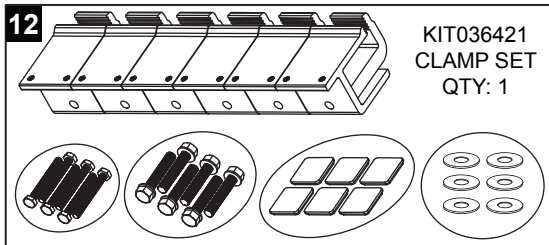
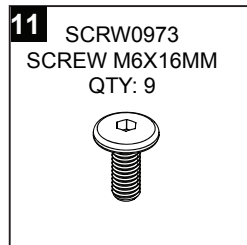
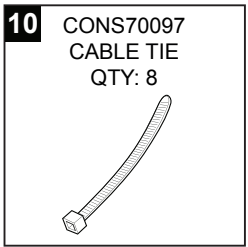
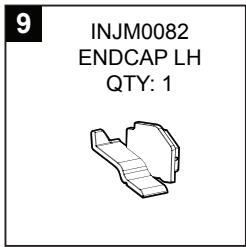
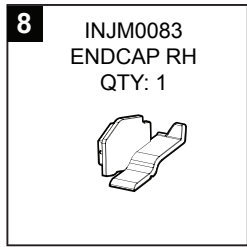

## KIT036423 EGR RollTrac FITTING KIT IN BOX

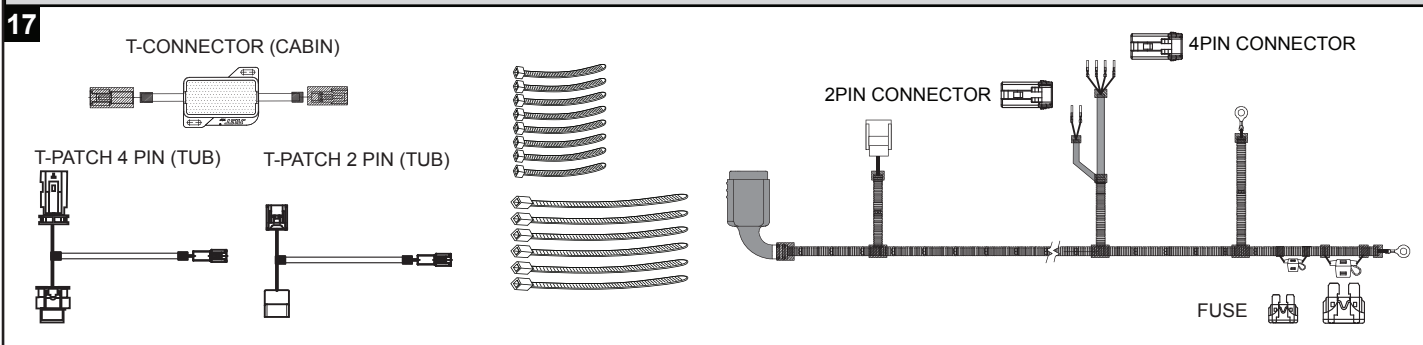

## EGR RollTrac FITTING KIT COMPONENTS IN BAGS



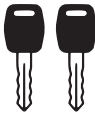
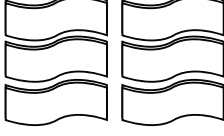
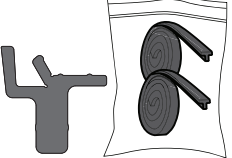
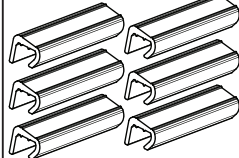

## EGR RollTrac FITTING KIT ADDITIONAL ITEMS

<p>INSTALLATION INSTRUCTIONS</p> 	<p>OWNERS MANUAL</p> 	<p>KEYS x2</p> 	<p><b>18</b> TAPE0698 TAPE 150X25MM QTY: 6</p> 
<p><b>19</b> RUBBER EXTRUSION QTY: 2</p> 	<p><b>20</b> CLAMP FOOT QTY: 6</p> 	<p><b>21</b> GROMMET x2</p> 	<p><b>22</b> TAPE0751 TAPE 3X12X1550MM QTY: 1</p> 

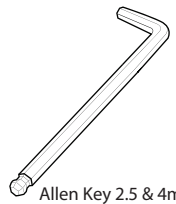
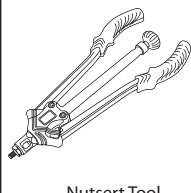

## TOOLS REQUIRED - NOT SUPPLIED IN KIT

 <p>Drill</p>	 <p>Holesaw Ø29mm Ø38mm Ø60mm</p>	 <p>Centre Punch &amp; Hammer</p>	 <p>Drill Stop Drill Bits Ø2.0mm Ø5.5mm Ø9.0mm</p>	 <p>Bobbin Sander Ø60mm</p>	 <p>Flat Screwdriver</p>
 <p>Phillips Screwdriver</p>	 <p>Tape Measure</p>	 <p>Scissors</p>	 <p>Masking Tape Fiberglass Tape Black Cloth Tape</p>	 <p>Non-permanent pen</p>	 <p>Spanners 8,10,13mm</p>
 <p>Ratchet &amp; Sockets 7,10,13mm</p>	 <p>Allen Key 4mm</p>	 <p>Allen Key 2.5 &amp; 4mm</p>	 <p>Torque Wrench</p>	 <p>Nutsert Tool</p>	 <p>Soapy Water</p>
 <p>50/50 Isopropyl Alcohol/Water</p>	 <p>ANTI RUST Rust Inhibitor</p>	 <p>Silicone</p>	 <p>Trim Removal Tool</p>	 <p>Side Cutters</p>	 <p>Step Drill Ø9mm</p>
<p>Cutting device needed to trim tubliner</p>	 <p>Anti-abresion tape to seal holes &amp; slots</p>	 <p>Silicone Spray</p>	 <p>6mm File</p>	<p><b>GLOSSARY:</b></p> <p><b>1</b> Number inside a square indicate part number</p> <p><b>1</b> Number inside circle indicate the sequence within a step</p> <p><b>1</b> Number inside the hexagon indicate torque instruction</p>	

## SECTION A

## TUB PREPARATION

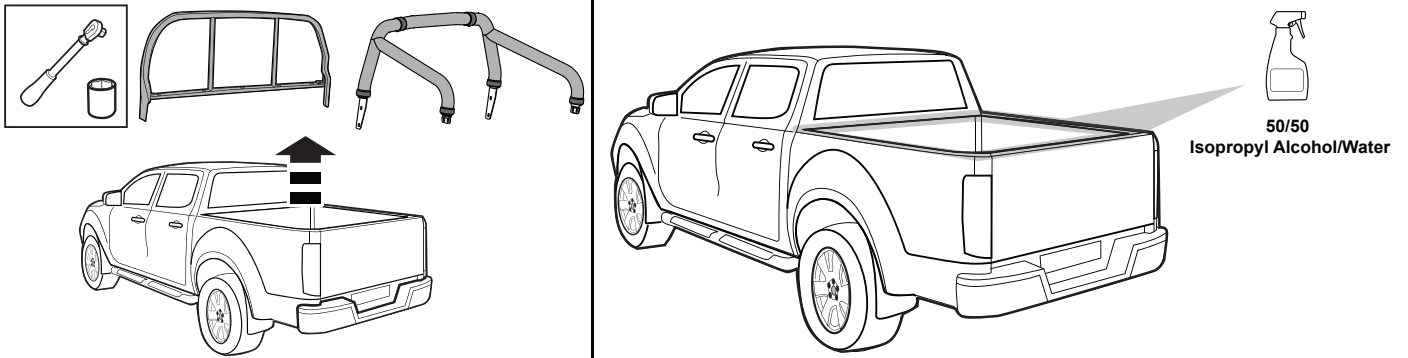

- 1** Carefully remove any accessories (Sports Bars, Cabin Guards, etc.) attached to the tub of the vehicle. Thoroughly wash the vehicle and tub and ensure that all dirt and grease is removed. Allow to dry. Clean the top surfaces of the tub and tailgate with a mixture of Isopropyl Alcohol and Water (50/50) and allow to dry.

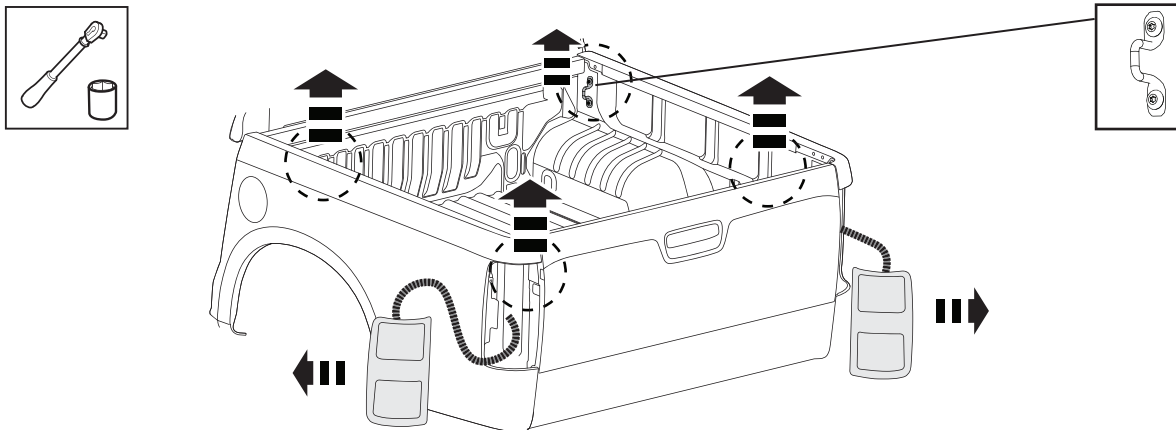

- 2** Carefully remove both Rear Tail Lamps with the appropriate tools and store in safe place. Retain all hardware for re-installation. Remove front and rear tie down hooks.



### TUB LINER TRIM NOTE:

Due to variations in tubliners it is strongly recommended that Installers mark up and pre check part fitment in assy and adjust trim lines prior to making final cuts. EGR will not be held responsible for incorrect or inaccurate liner trimming.

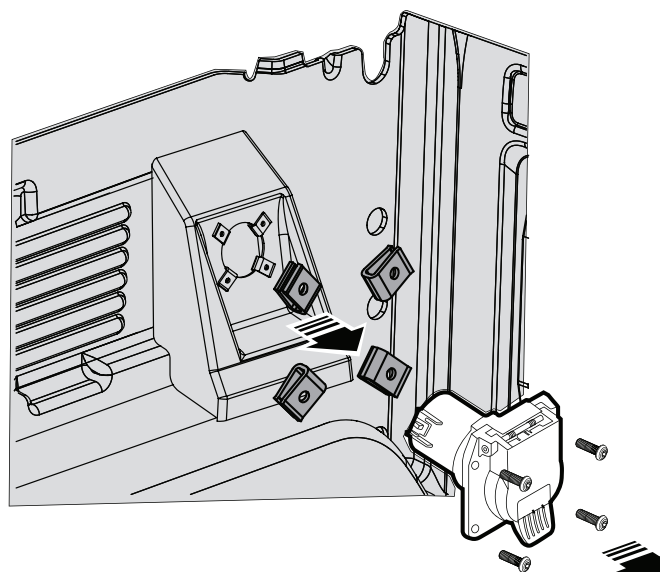

- 3** Remove and retain the power socket if fitted.

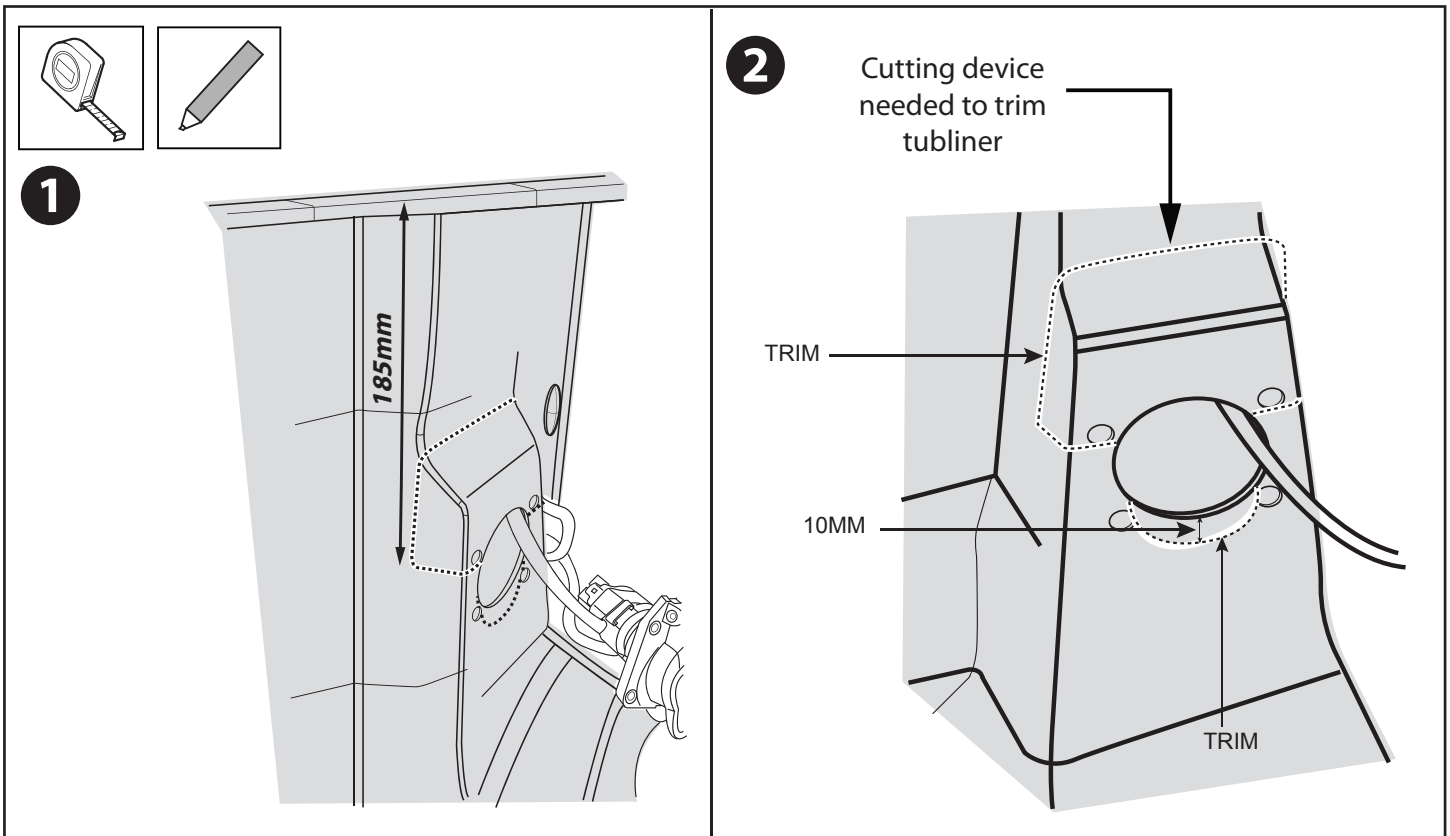

**4** Please mark trim line 185mm from the top surface of the tub as shown. Trim the tubliner as per the image and refit the power socket. Tighten all the fasteners which have been removed in the previous step.

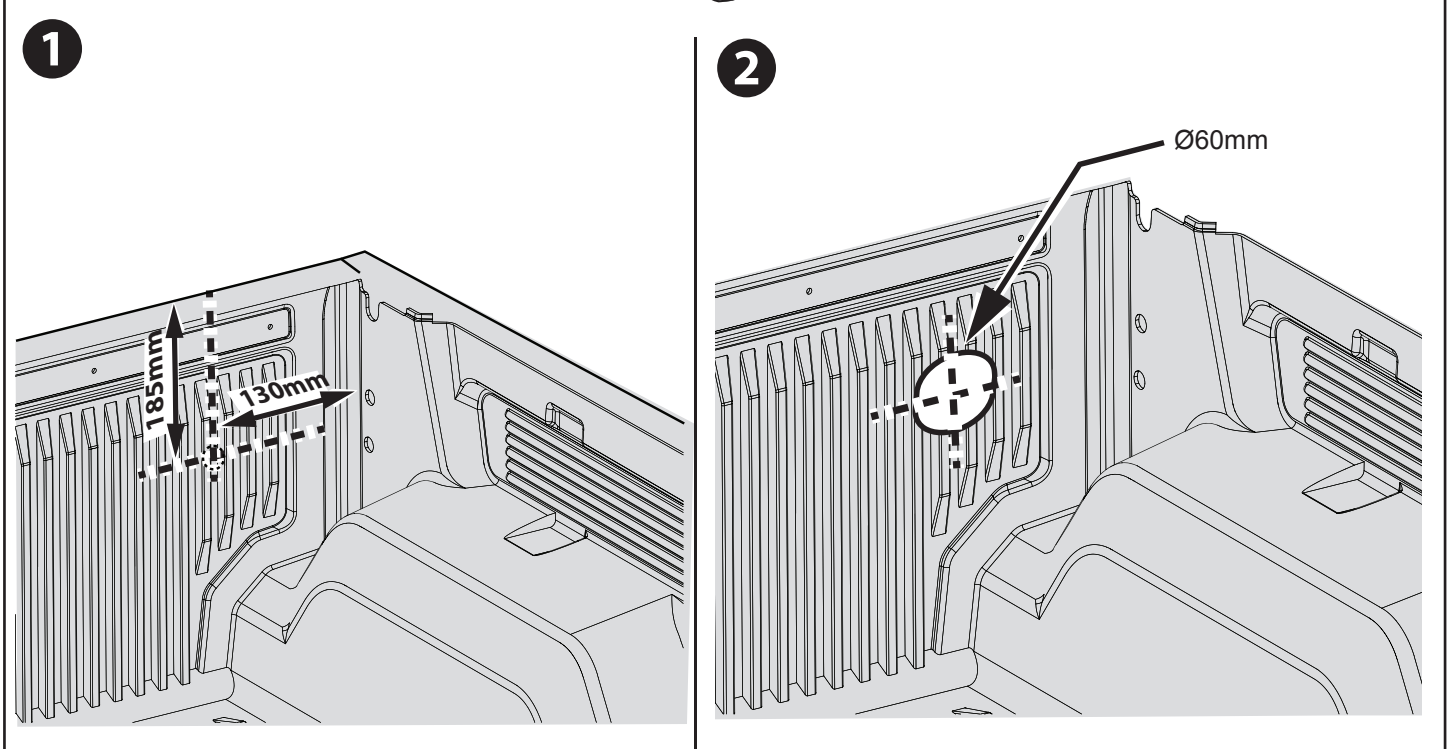
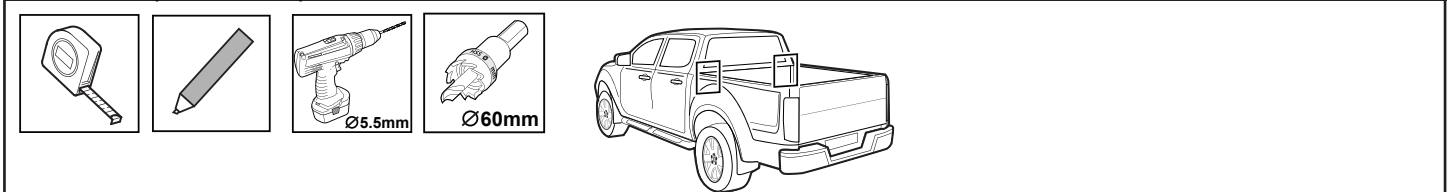

**5** Measure and mark up the positions for the front Drain Tubes on both sides. Centre punch the locations and drill through the tub and tubliner (if fitted) with 5.5mm drill as shown. Drill out the front pilot holes in the tubliner with 60mm holesaw. RHS shown, repeat for the LHS.  
**Note: If needed remove the tubliner.**

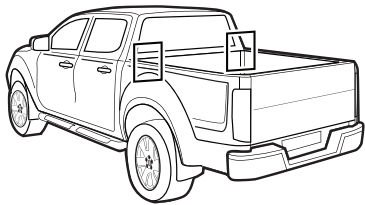
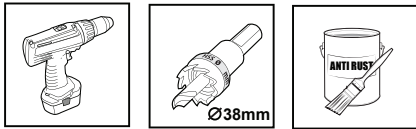

FRONT OF TUB  
RHS SHOWN LHS MIRROR

130mm

185mm

**ATTENTION:** Ensure that the diameter of the hole does not exceed 38mm. Larger hole size will lead to water ingress into the tub

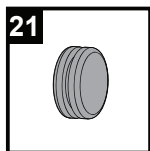
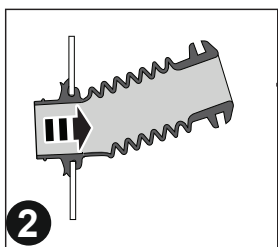
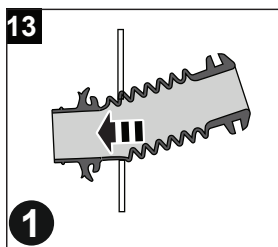

**INSTALL FRONT DRAIN TUBES TO TUB**

**6** Mark the position of the front drain holes in the tub front panel and drill with 38mm holesaw. Clean all burrs and coat the exposed metal with a suitable rust preventative (not supplied). Fit rubber grommets into the existing holes in the tub as shown. Refit tubliner and tie down points. Fit front drain tubes (13) to the tub.

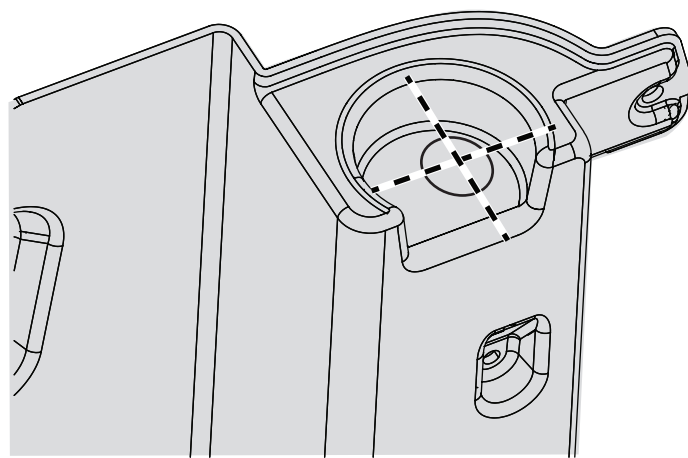
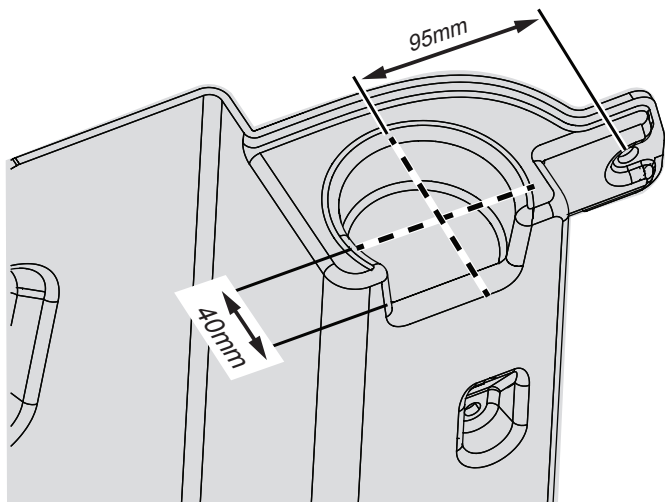
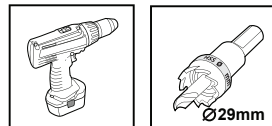
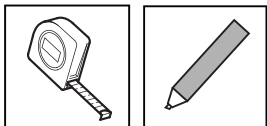

**7** Measure and mark up the positions for the rear Drain Tubes on both sides of the tubliner if fitted. Drill the locations with 29mm holesaw.

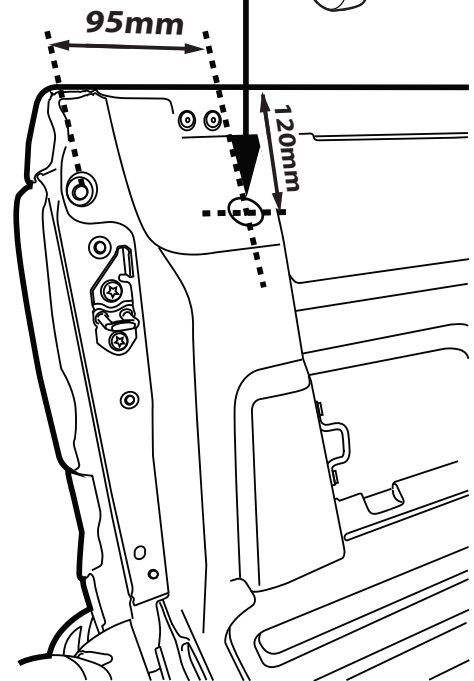
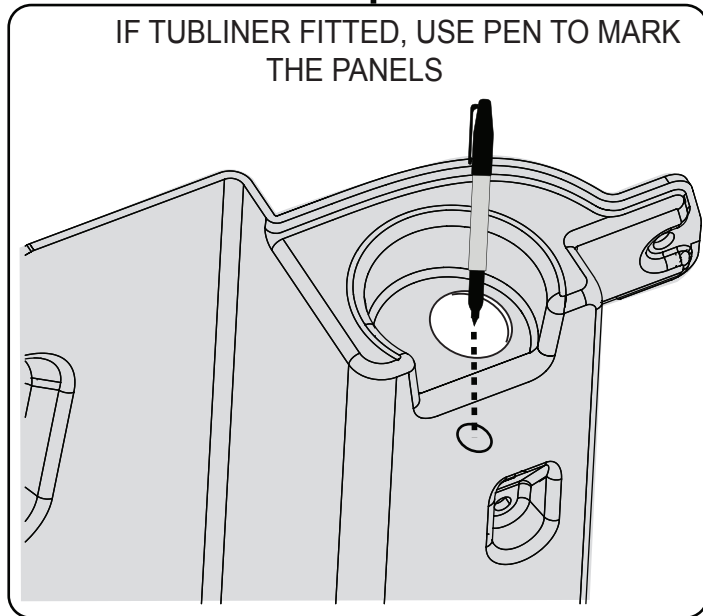
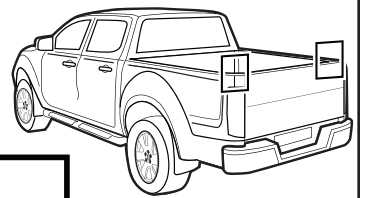
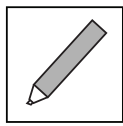
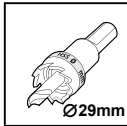
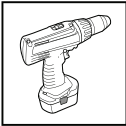

- 8** Mark the position of the rear drain holes in the tub rear panels, centre punch the hole and drill with 29mm holesaw. If no tubliner fitted, use the dimensions provided. Clean all burrs and coat the exposed metal with a suitable rust preventative (not supplied).

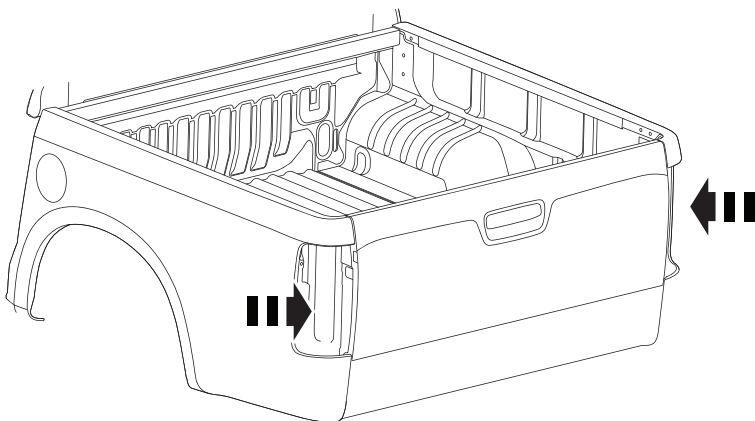
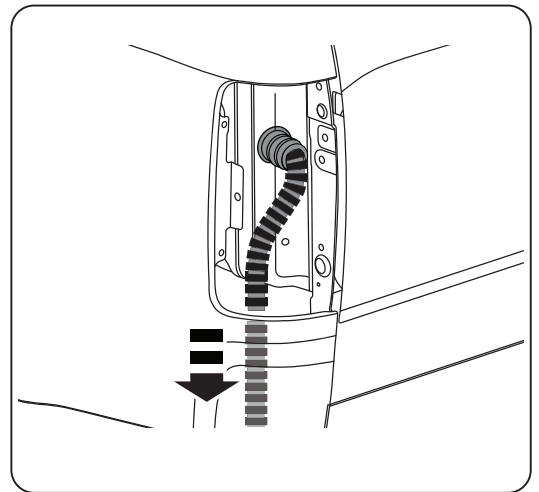
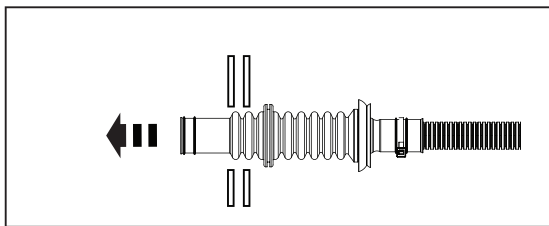

- 9** Install the rear drain tubes and water conduit (14) into the gap in the LHS and RHS tail lamp recess.



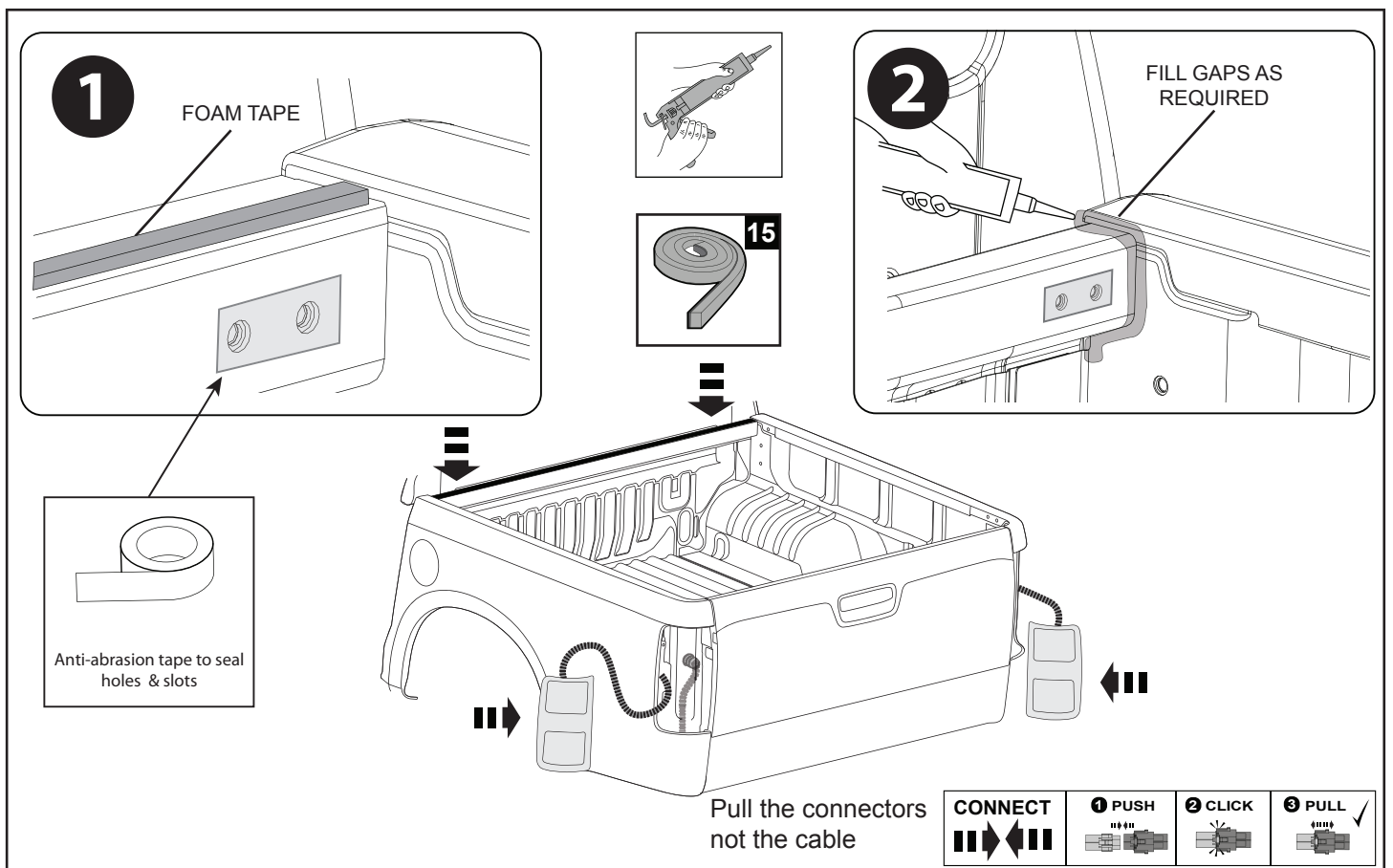

- 10** Clean the tub top with isopropyl alcohol (50/50) and use primer. Allow to dry. Apply foam tape (15) to the top of the front tub rail close to the rear edge of the rail as shown. To prevent water ingress, apply a bead of silicone (non-acidic) to gaps such as between the front rail and the side rail as shown. Holes in the tub from any removed accessories should be covered using tape or silicone.
- NOTE:** Ensure the Silicone bead transitions smoothly between front and side rail. Re-connect the rear tail lamps with the previously removed hardware.

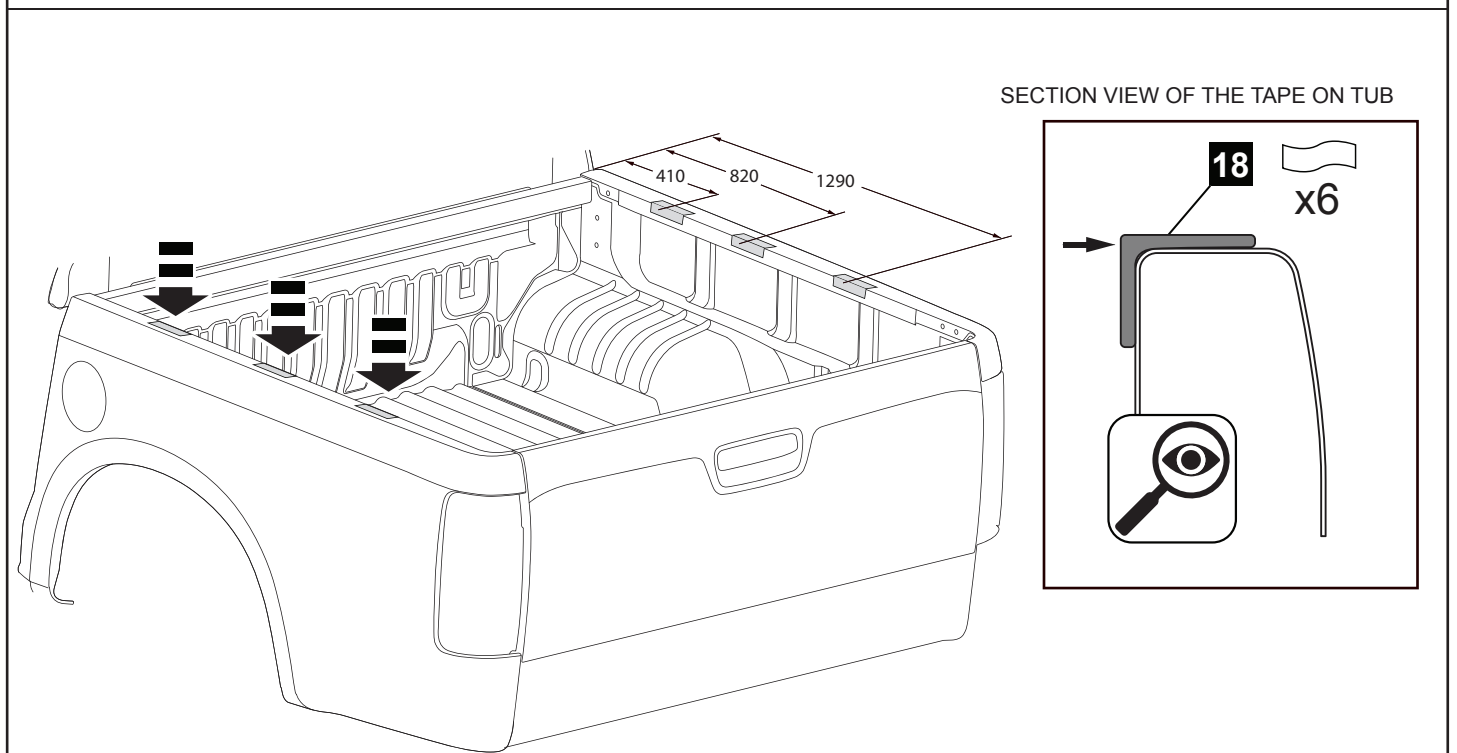

- 11** Clean top of the tub. Measurements taken from front of the tub to the centre of each tape, as per the diagram. Adhere 6 Abrasive Protection Strips (18) to the top of the tub at clamp locations. Position the tape so that it is aligned with the inside wall of the tub as shown.

## SECTION B

## OVERVIEW OF ELECTRICAL LOOM INSTALLATION



**IMPORTANT: DISCONNECT CAR BATTERY NEGATIVE TERMINAL.  
FIT THE SUPPLIED FUSES AT THE END OF INSTALLATION.**



**WHILE ROUTING THE VEHICLE HARNESS AVOID ANY VEHICLE COMPONENTS  
THAT HEAT UP, LIKE EXHAUST AND ENGINE COMPONENTS.  
DO NOT ATTACH HARNESS TO FUEL LINES AND AVOID PINCH POINTS.**

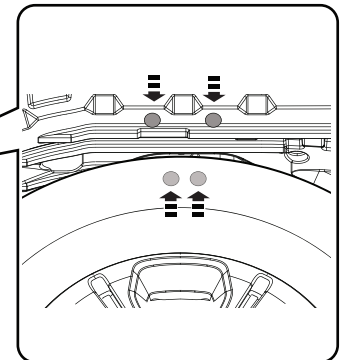
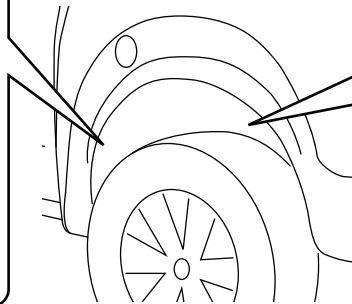
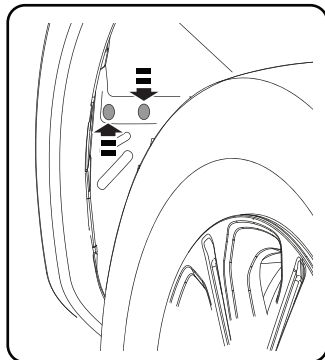
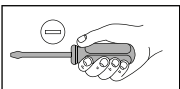
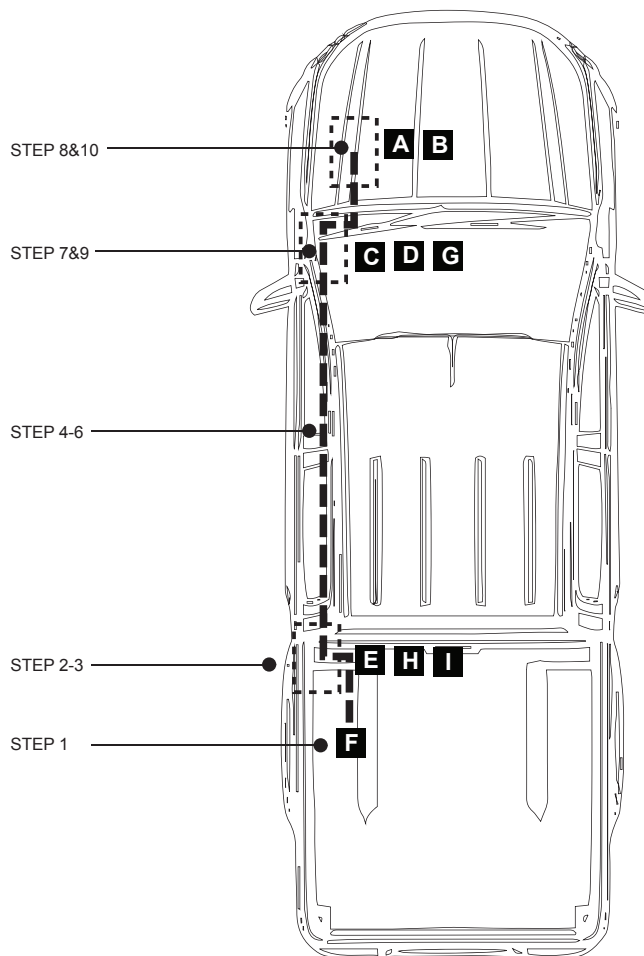
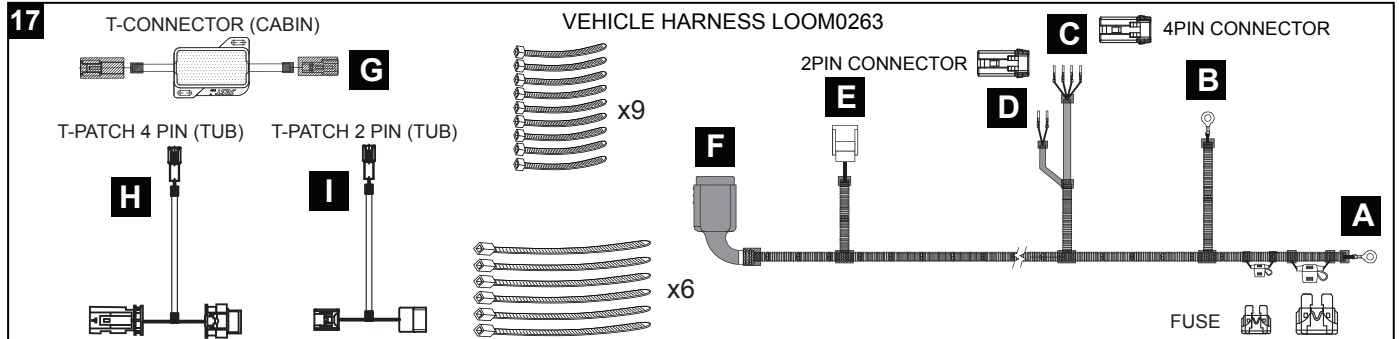

**1** Carefully remove the rear left inner fender by removing the six screws.

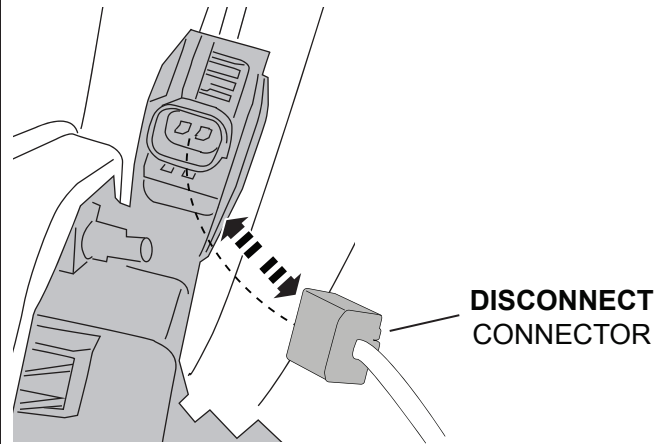
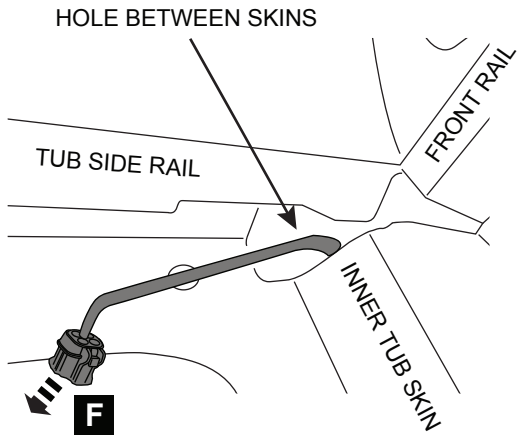

- 2** Starting from the chassis rail in front of the LHS rear wheel, feed the Vehicle harness (branch F) up between cabin and tub into the opening in the tub front left hand corner until approx 300mm protrudes. Disconnect fuel flap connector.

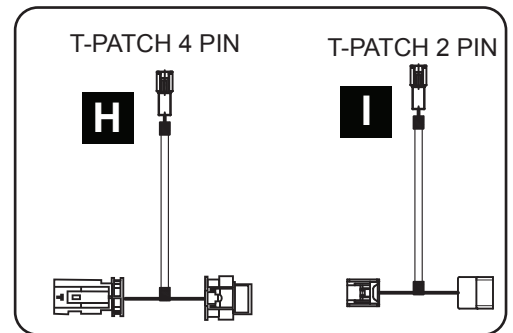
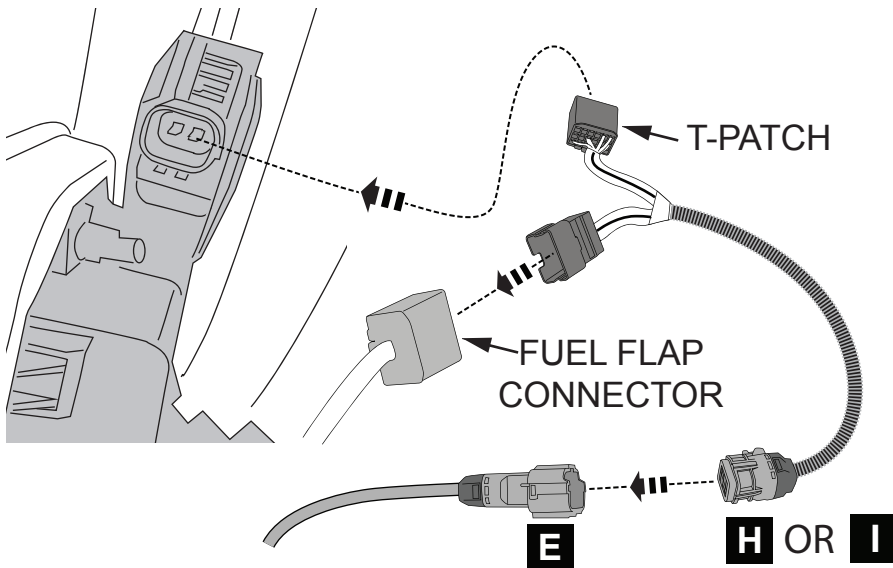

- 3** Connect T-patch (H or I) male connector to female connector and female connector to male connector. Connect the T-patch connector (H or I) to the RollTrac harness (E). Secure all cables inside the inner flender by using cable ties. Refit the inner flender by reusing the removed 6-screw. **Note:** For different vehicle models, 2-pin and 4-pin T-patch are provided in the RollTrac harness bag.

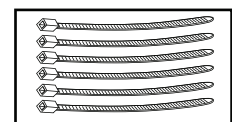
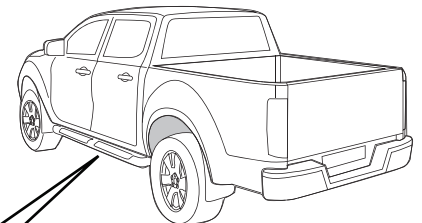
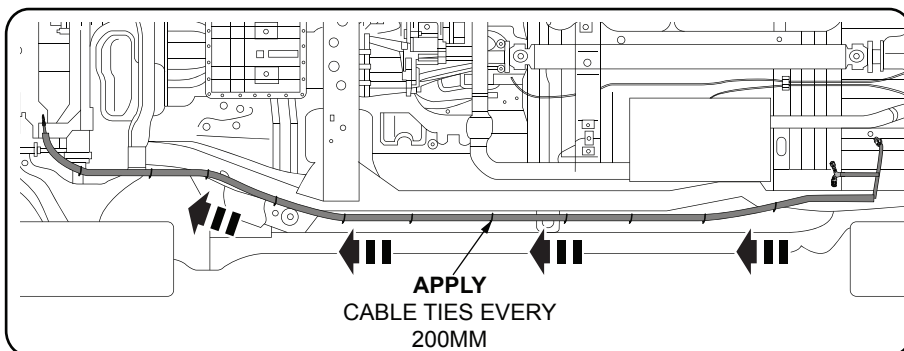

- 4** Run the rest of the harness forward along the chassis rail and loosely secure using supplied cable ties every 200mm (Avoid any pinch points such as rubber shock absorbers).

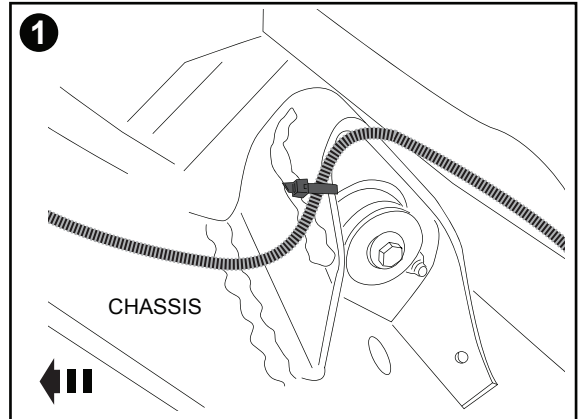
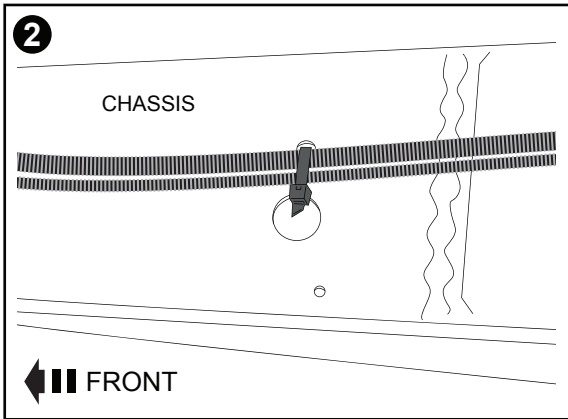
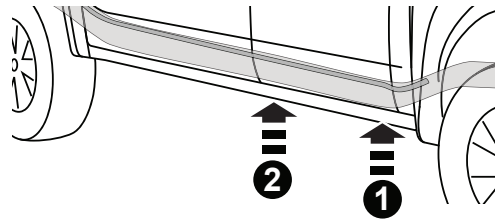
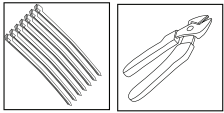

**5** Attach the wiring to the chassis rail using hole in the tab mount, use cable tie.

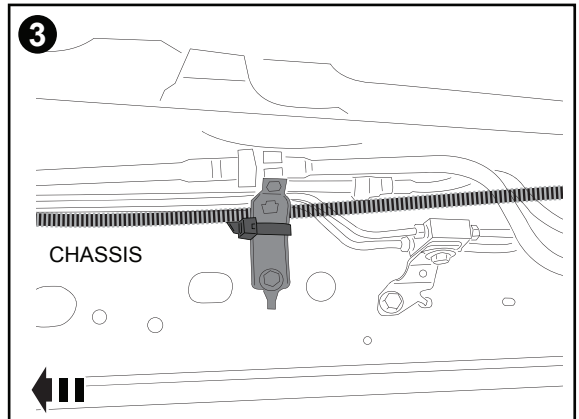
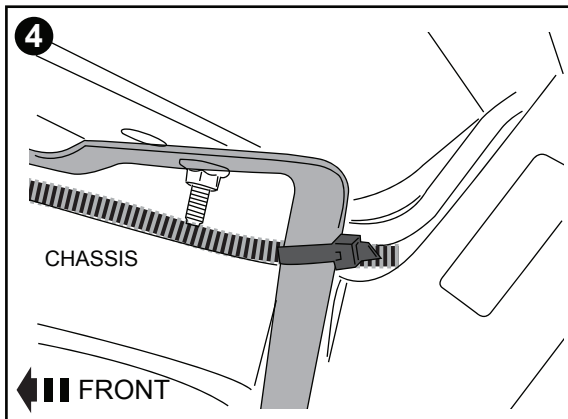
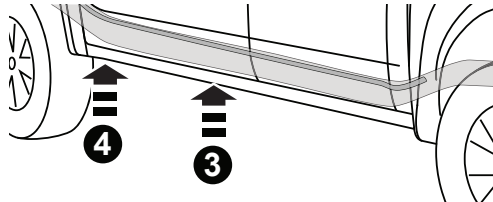
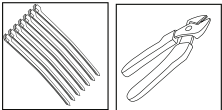

**6** Attach the wiring to the bracket next to the brake lines along chassis rail using cable tie.  
Attach the wiring to the L-shape bracket holding plastic ducting under the engine bay using cable tie.

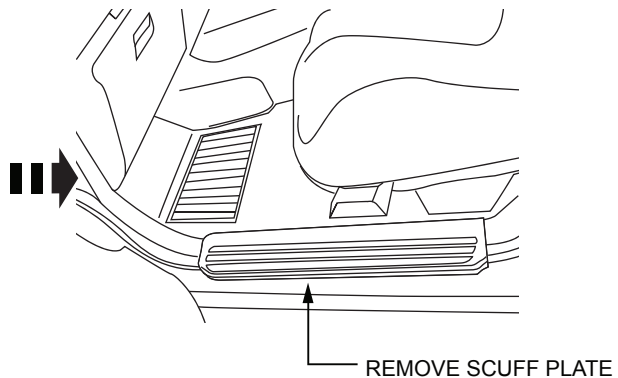
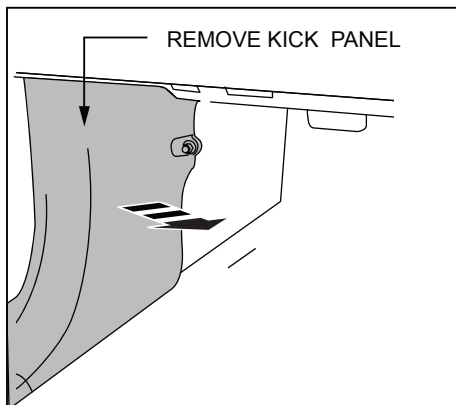

**7** At the front left hand foot well remove the kick panel and door scuff plate.

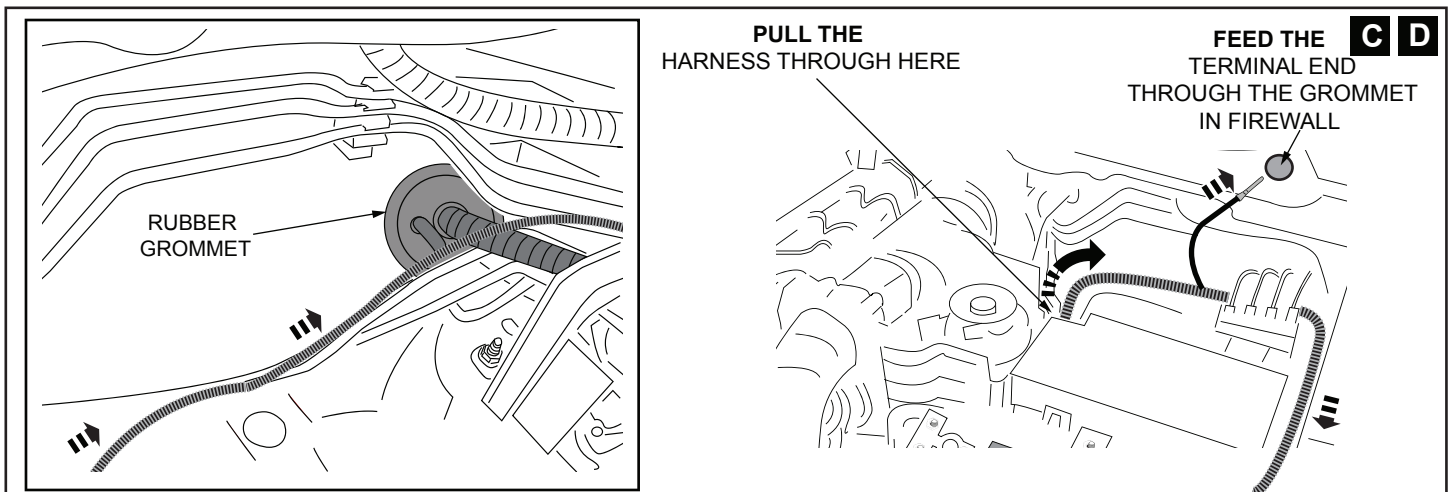

**8** Pull the wiring into the engine bay. Push the single wire through the rubber grommet in the fire wall. Tuck the wiring along the fender towards the battery. **Note:** Cut the LHS access point to feed the wire through.

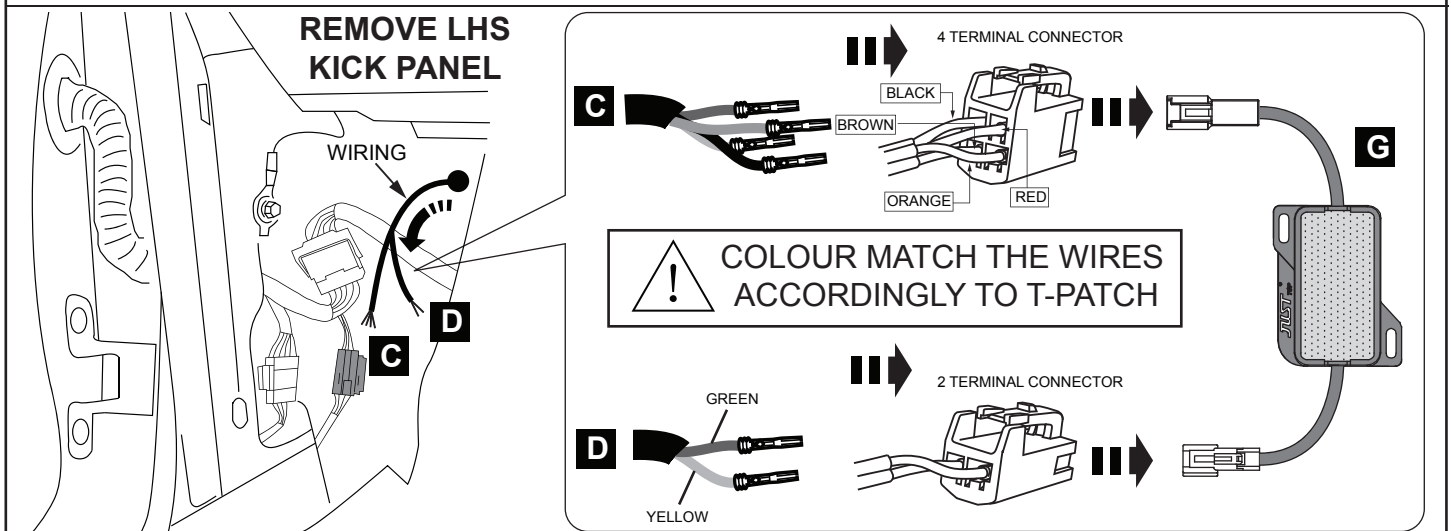

**9** Pull the wiring loom into the cabin. Fit the 4 terminals (black, red, orange & brown) on the Vehicle Harness into the Male terminal housing. Connect the T-connector to the Vehicle Harness. Fit the 2 terminals (yellow/green) on the vehicle harness into the male terminal housing. Connect the T-connector to the vehicle harness and refit the removed kick panel first, than scuff plate with the seal.

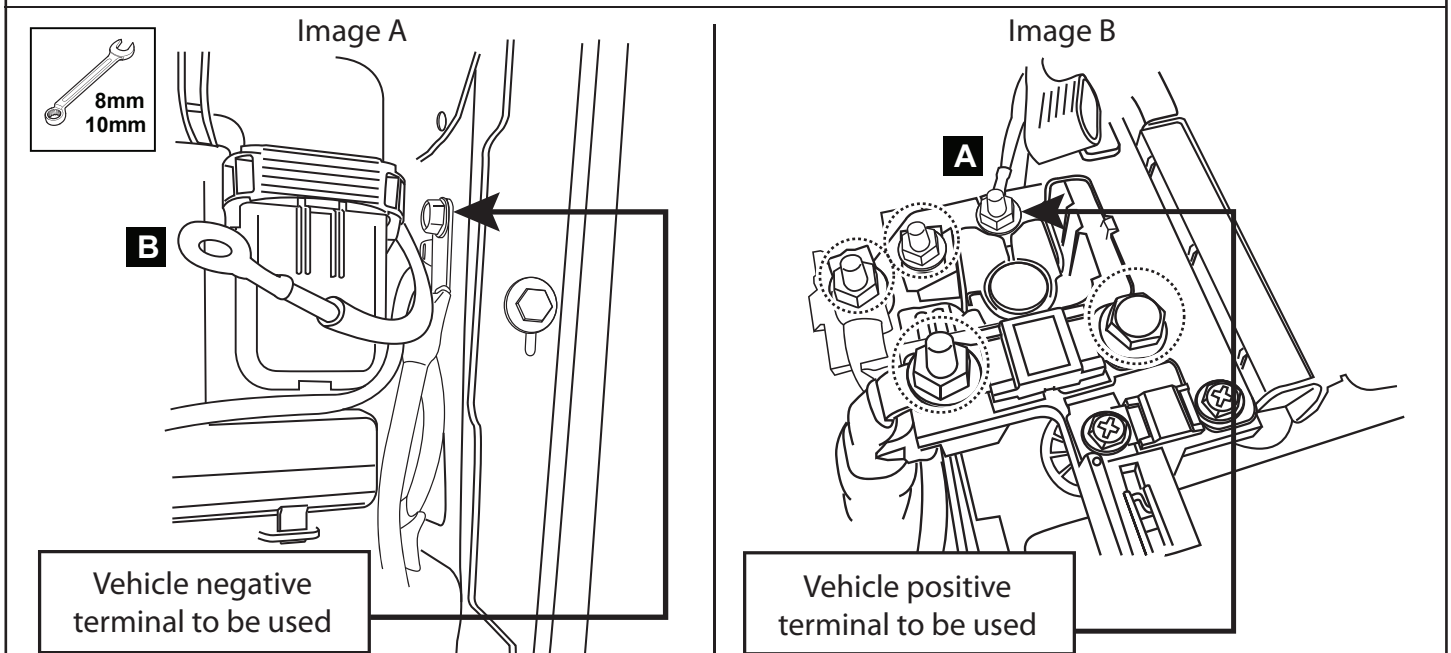

**10** Connect the Vehicle Harness to the negative terminal which is located as per image A. Do not connect the vehicle harness to the negative terminal of the battery. Connect the positive terminal of the vehicle harness to the bolt on the terminal of the battery as shown in image B. Do not connect the positive terminal of the vehicle harness to any of the studs encircled in image B. **IMPORTANT:** Tighten all cable ties and trim any excess.



DURING ASSEMBLY PROCEDURE SUPPORT AT CENTRE OF CANISTER ONLY, PLACE ON TOP AND BASE CARTON (OR SIMILAR), COVER WITH FOAM BLANKET. TO AVOID SCRATCHING POWDERCOATED SURFACES. DO NOT LOAD ELECTRICAL CONNECTORS OR MOTOR COVER.

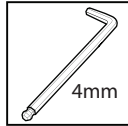
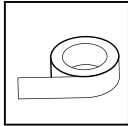

3

RHS FIT FIRST



LHS 4

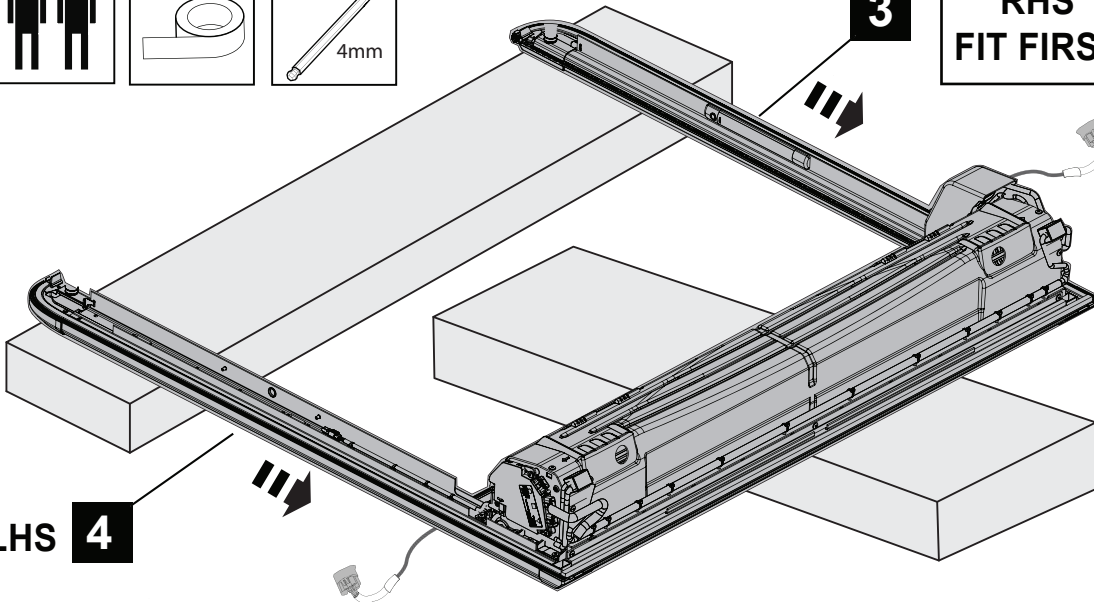

1



ATTENTION: SEAL MUST FACE IN THE DIRECTION AS SHOWN. WARRANTY VOID IF ASSEMBLED INCORRECTLY.

HOLD SEAL FLAT USE CLOTH TAPE

RHS SHOWN

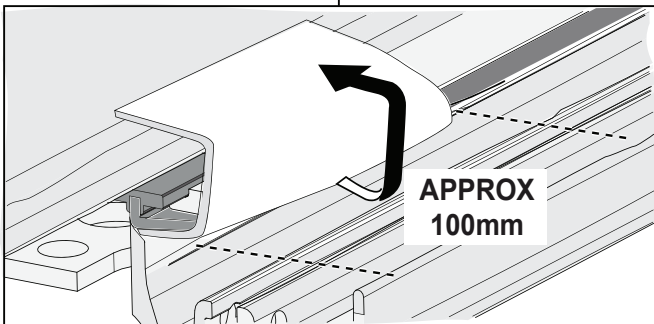
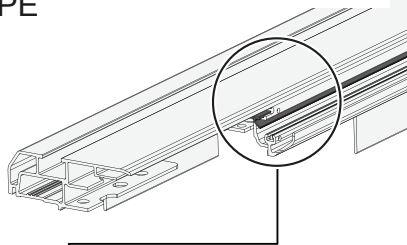
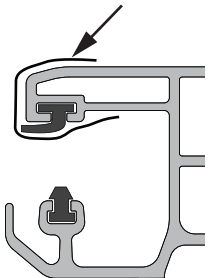

2



ATTENTION: EXPOSE 3 SLATS PRIOR TO FITTING SIDE RAILS.

ENSURE ENDS ARE ALIGNED

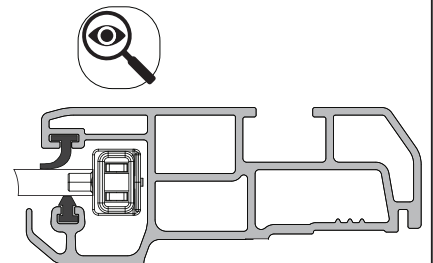
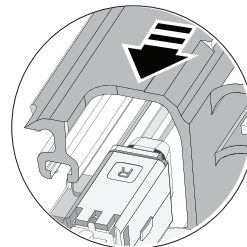
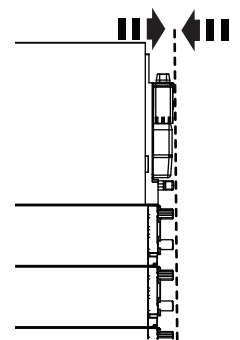

1

Place the canister (1) on two protected boxes as shown, ensure hand rail and slat ends are aligned. Tape up the seal on the Side Rail (3) as shown.

**IMPORTANT:** Carefully align and slide the rail over the handrail contact and canister endplate taking particular care to ensure that the siderails are slid straight and no undue force is applied to the electrical contact. Details in following steps.

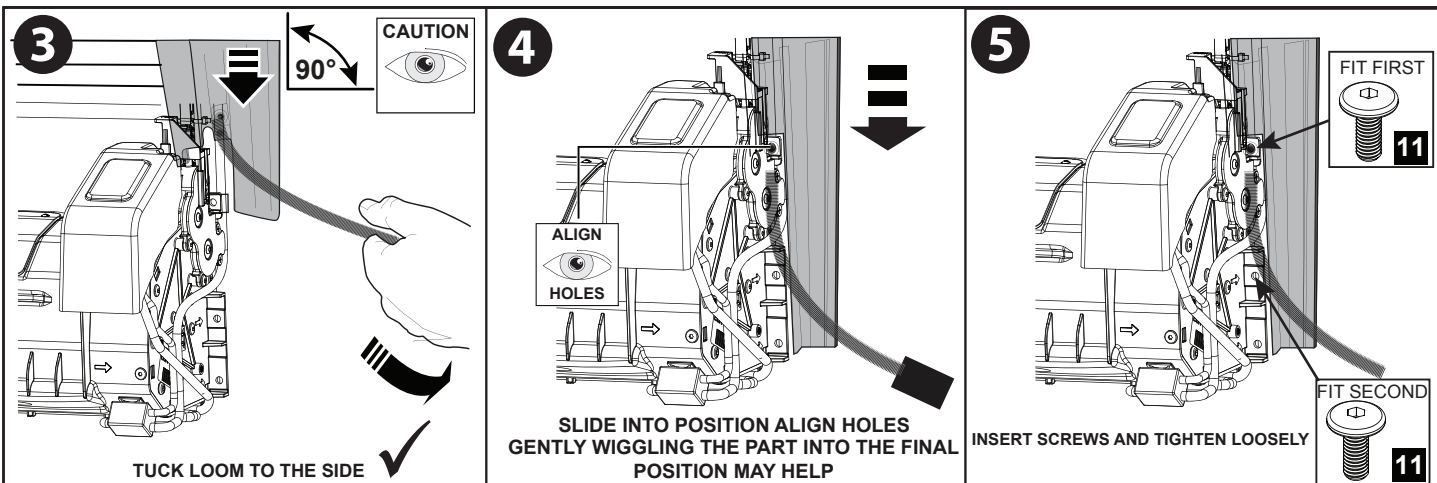

**2** Pull hand rail to expose 3 slats. Slide the RHS Rail over slat ends and onto endcap location pins. Align the holes and secure loosely with two screws (11). Do not tighten. Repeat for LHS Rail (4)

DURING ASSEMBLY PROCEDURE SUPPORT AT CENTRE OF CANISTER ONLY, PLACE ON TOP AND BASE CARTON (OR SIMILAR), COVER WITH FOAM BLANKET. TO AVOID SCRATCHING POWDERCOATED SURFACES. DO NOT LOAD ELECTRICAL CONNECTORS OR MOTOR COVER.

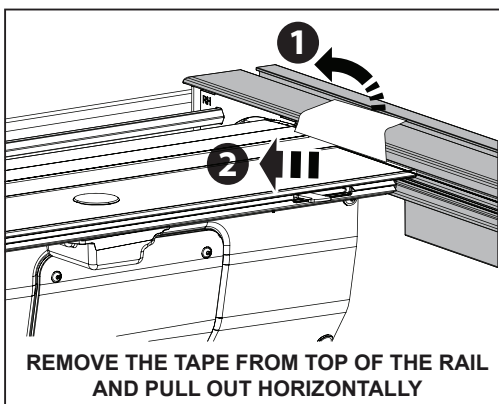
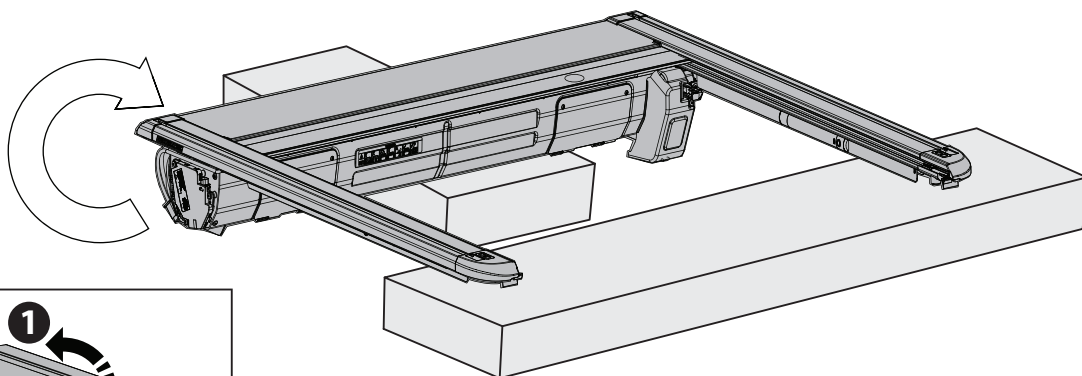

**CAUTION**  
  
 ALIGN CAREFULLY

**ATTENTION: SEAL MUST FACE IN THE DIRECTION AS SHOWN. WARRANTY VOID IF ASSEMBLED INCORRECTLY.**

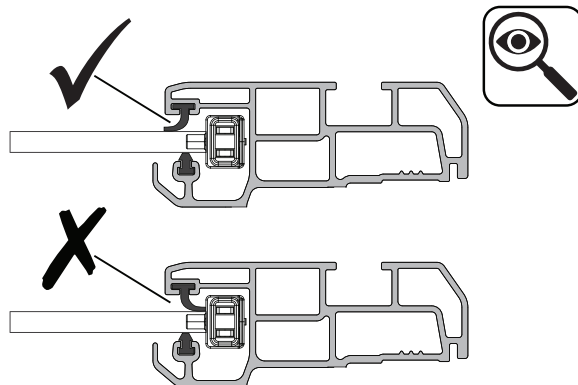
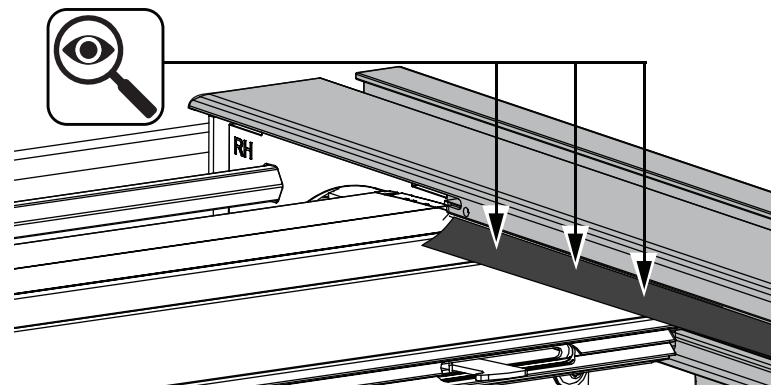

**CHECK SEAL IS IN POSITION AND NOT DAMAGED**

**3** Carefully lay the assembly over onto a protected surface. Remove the tape holding the rubber seal and check the seal position as shown. Repeat for LHS Rail (4)

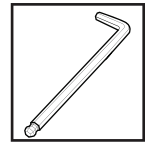

SIDE VIEW

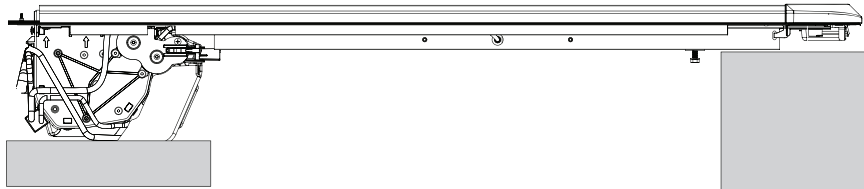

REAR VIEW

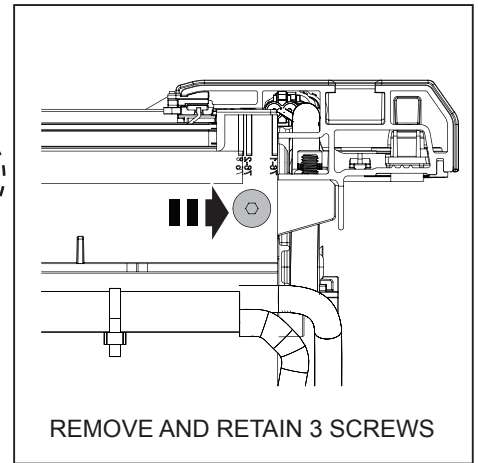
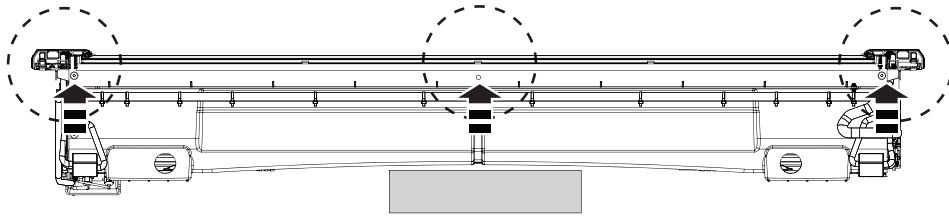

REMOVE AND RETAIN 3 SCREWS

**4** Remove the 3 pre-fitted screws (11) from the rear of the cover which will be used to secure the Front Plate (1) to the assembly. Ensure the product is not scratched or damaged when laying flat.  
**IMPORTANT:** Do not apply load to the electrical connectors and do not sit product on motor cover.

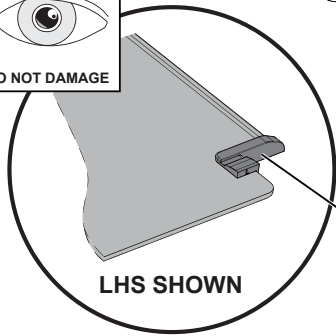

LHS SHOWN

REMOVE TAPE SECURING THE RUBBER CORNER SEAL

**ATTENTION:** Remove foam tape end from the side rail before fitting into front cover

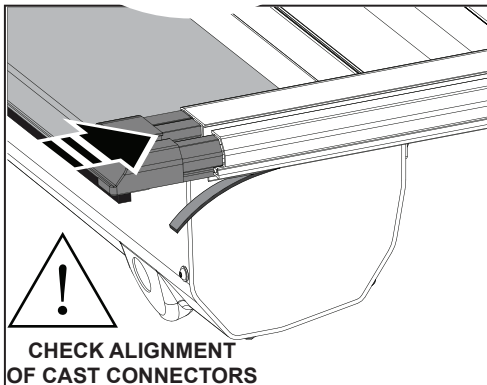

CHECK ALIGNMENT OF CAST CONNECTORS

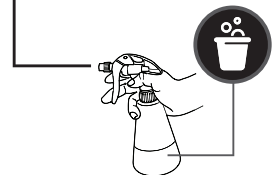
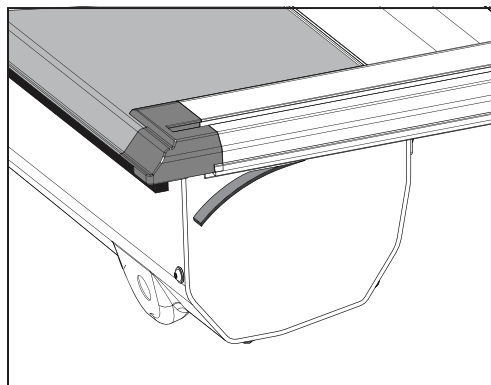

**5** Slide the Front Plate (2) over the canister and into the side rail channels ensuring that the foam side rail tape is pulled out of side rail and the small rubber corner seal on the RHS and LHS of the front plate are not damaged.  
**IMPORTANT:** Spray the front cover edge with soapy water to allow it to slide easily into the sides, twisting side rails outwards will also help.



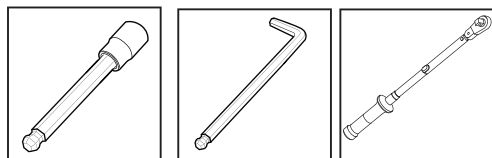

REAR VIEW

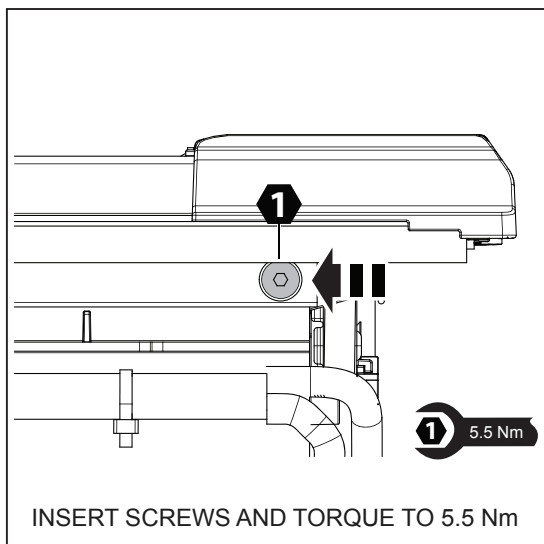
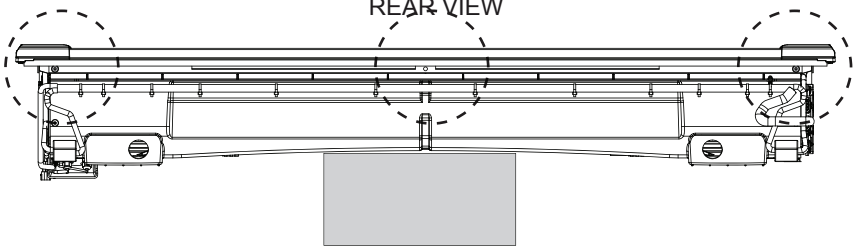

**6** Using the 3 screws removed from Step 4, screw the Front Plate (2) to the Canister Assembly (1) and torque to 5.5 Nm.

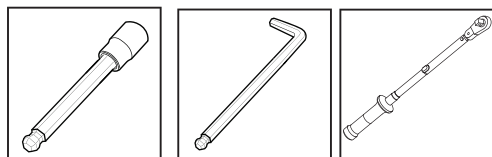

SIDE VIEW

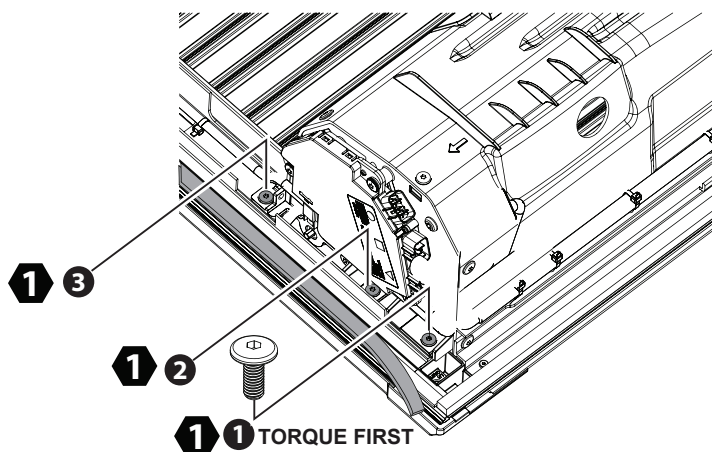
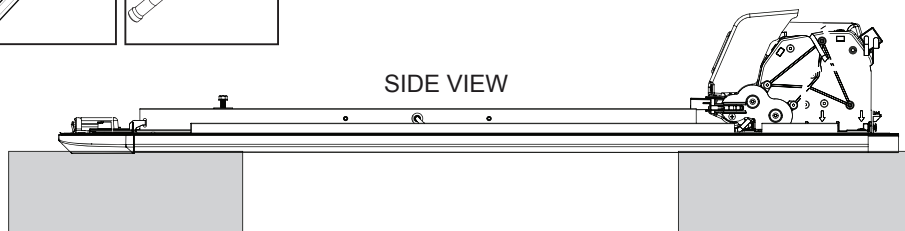

LHS SHOWN - RHS IS A MIRROR IMAGE

**7** Carefully flip the assembly over onto a flat protected surface which will not damage the cover or scratch the paint work. Install the 2 screws (11) at the most rearward position first through the front cover to the side rails and torque to 5.5Nm followed by the remaining 4 screws (11) and torque to 5.5Nm.

LHS SHOWN - RHS IS A MIRROR IMAGE

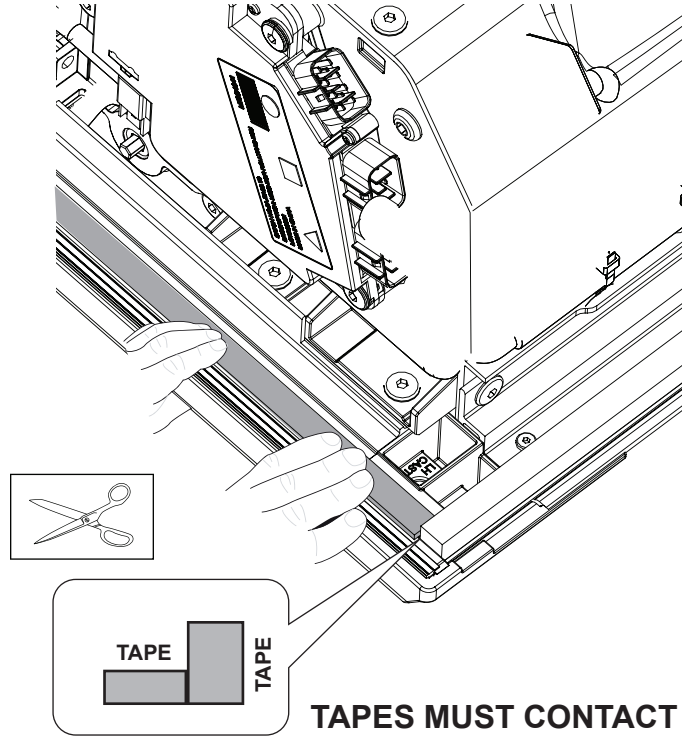
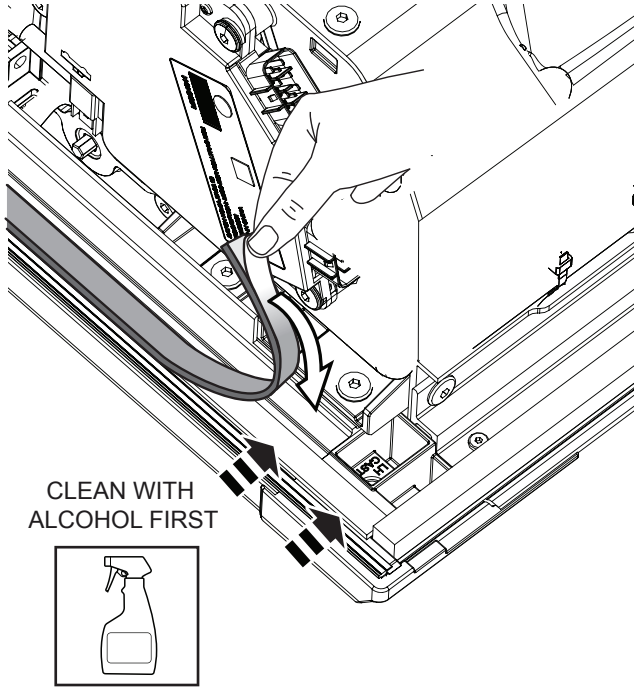

**8** Clean powder coated surface first with alcohol spray. Trim foam tape length to ensure the end will butt against front cover seal - avoiding any gap. Peel the protective liner from the foam tape, adhere to the channel in the side rail, Press down firmly to secure. Repeat on RH side rail.

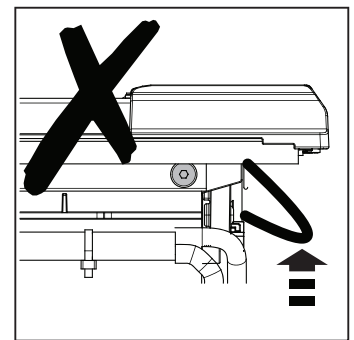
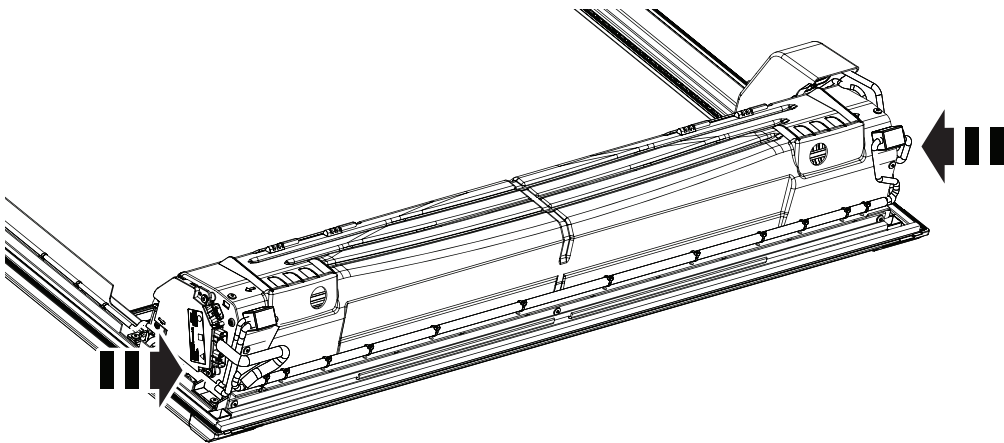

SECURE ALL CABLES TO PREVENT PINCHING

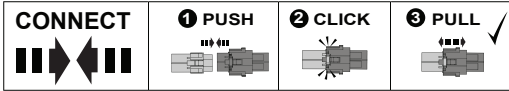
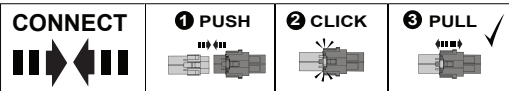

PULL THE CONNECTOR NOT THE CABLE

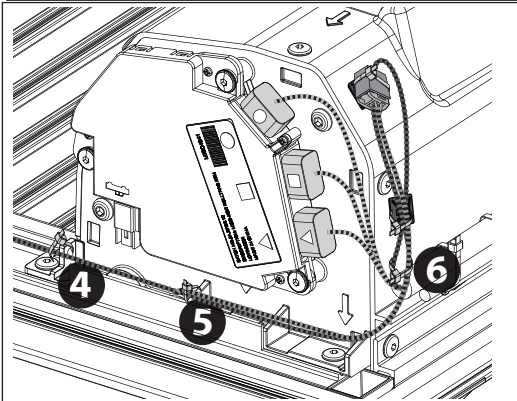
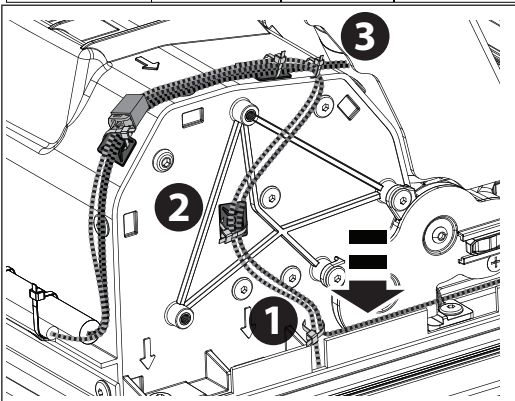

**9** Connect side rail harness connectors to the connectors on the canister on the LHS and RHS. Secure the harness to the canister using cable ties at the six locations shown. Secure with zip ties and pads. Ensure all cables are retained to prevent pinching during installation.

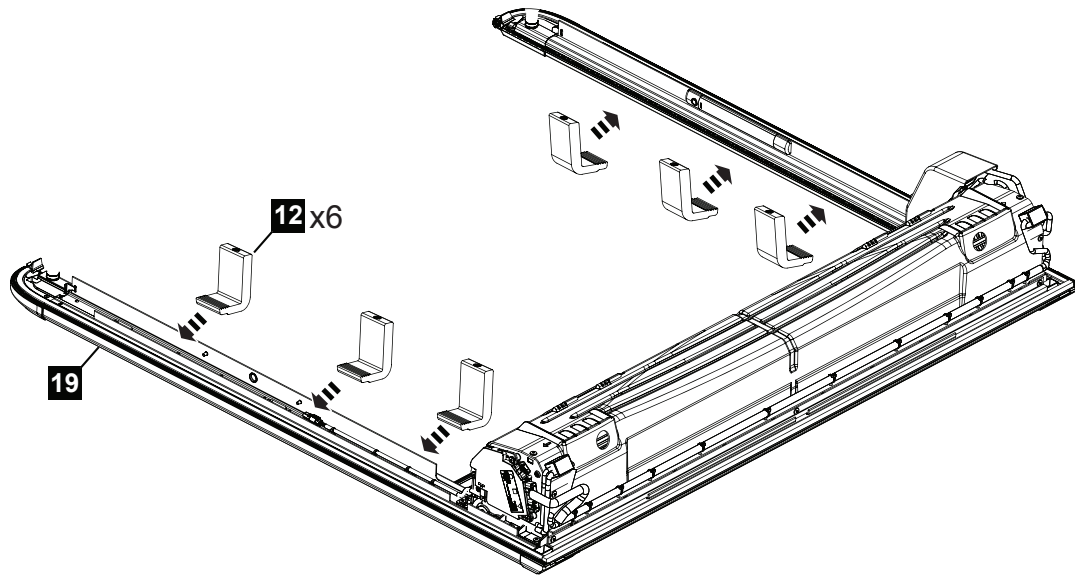
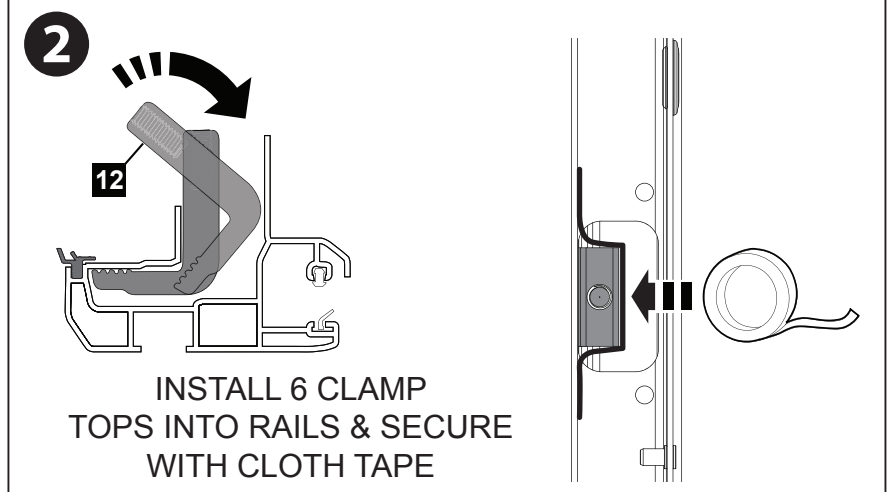
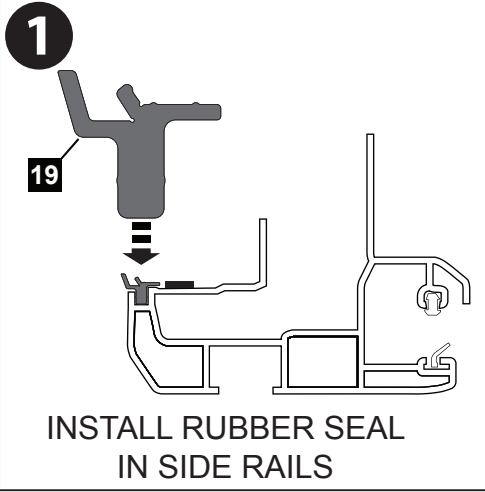

- 10** 1. Install the Rubber Perimeter Seal into each side rail and ensure seal is firmly seated (note the seal orientation). **Important:** do not stretch the seal while fitting.
2. Install the six Clamp Tops (12) into the LHS and RHS side rails and secure with cloth tape to temporarily hold in position.

CONTINUE ON THE NEXT PAGE

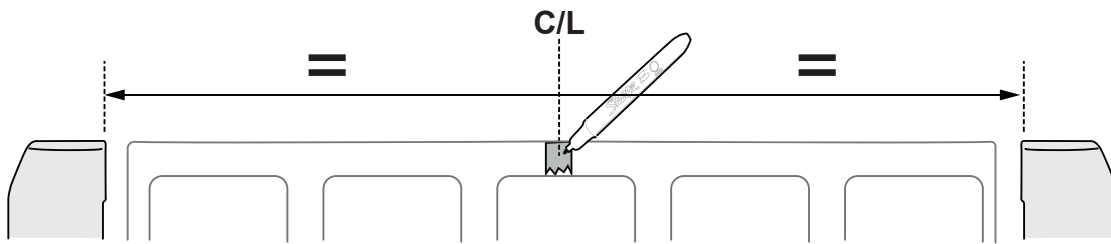
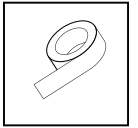
**1** (VIEW INSIDE)

MARK CENTRELINE ON THE TAILGATE  
(MEASUREMENTS TAKEN FROM INSIDE TUB AS SHOWN)

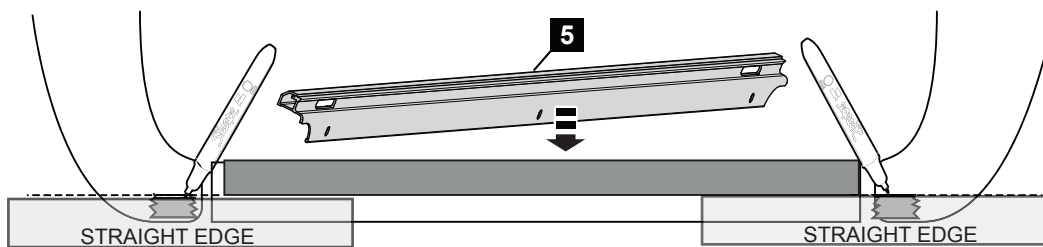
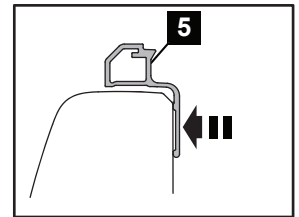
**2** (TOP VIEW)

MARK LINE ON LHS AND RHS

**1** Measure the tailgate opening distance, determine the centre point and mark on a strip of tape placed on the tailgate as shown.

Install and centralise the Tailgate Rail (5) in position, ensuring the rail is sitting flush up against the tailgate. Place a straight edge as shown and mark a line on each side of the tub on the masking tape. Remove the Tailgate Rail (5).

CONTINUE ON THE NEXT PAGE



HEAVY

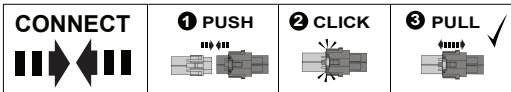
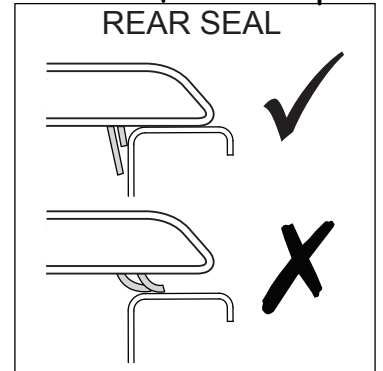
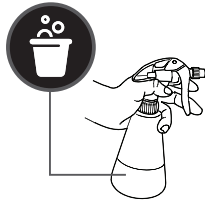
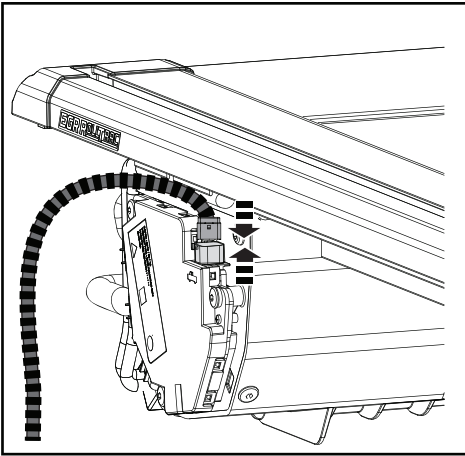
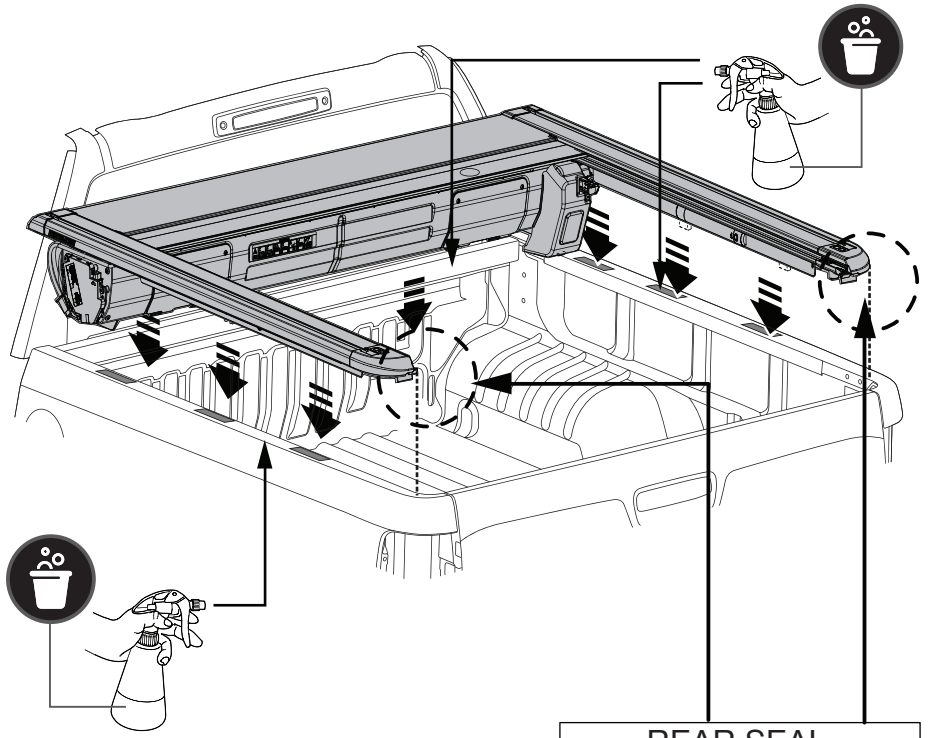

PULL THE CONNECTORS  
NOT THE CABLE

**2** Spray the top surface of the tub liberally with a soapy water solution to enable the Cover to slide easily. Using two people to lift the cover from both sides and carefully lower it onto the tub. Connect the vehicle harness to the ECU as shown. **NOTE:** You may have to lift the LHS of the cover and use packer to aid connection. Ensure rear seals are sitting vertically as illustrated.

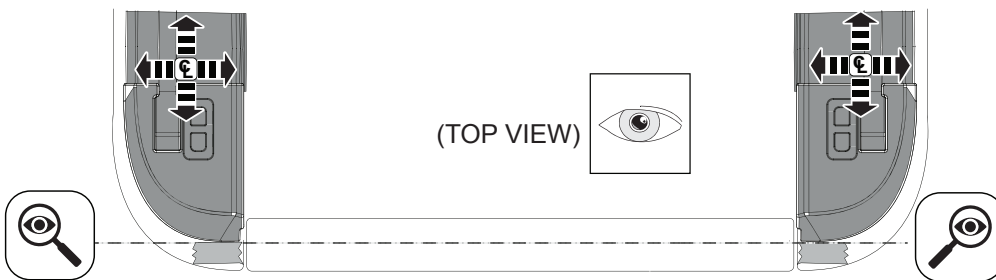

CENTRALISE AND ALIGN THE COVER TO THE MARKINGS

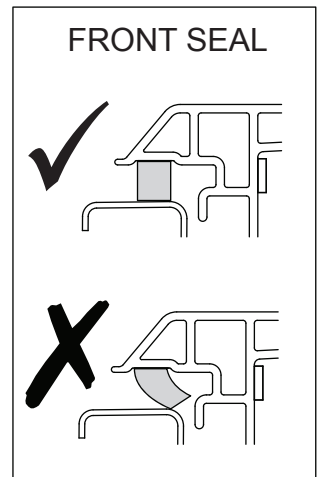

**3** Adjust the cover so that it is aligned with the previous markings as shown. Ensure seals are not deformed by lifting cover and dropping vertically on tub.

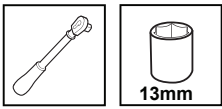

13mm

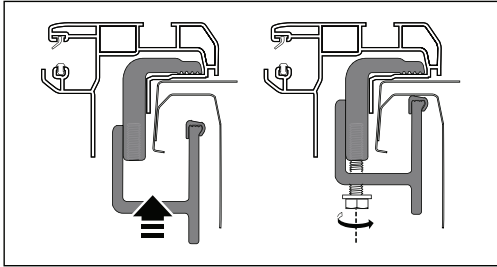
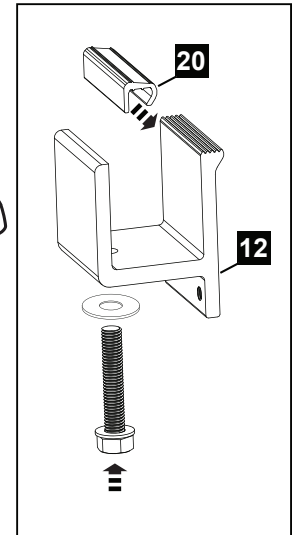
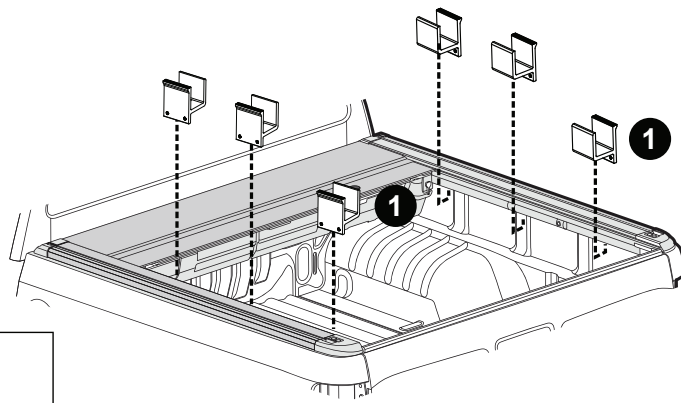

**4** Slide the clamp feet (20) onto the clamp base and loosely install the LHS and RHS clamp bases (12). DO NOT TIGHTEN. IMPORTANT: Ensure to install washers as supplied in the kit.

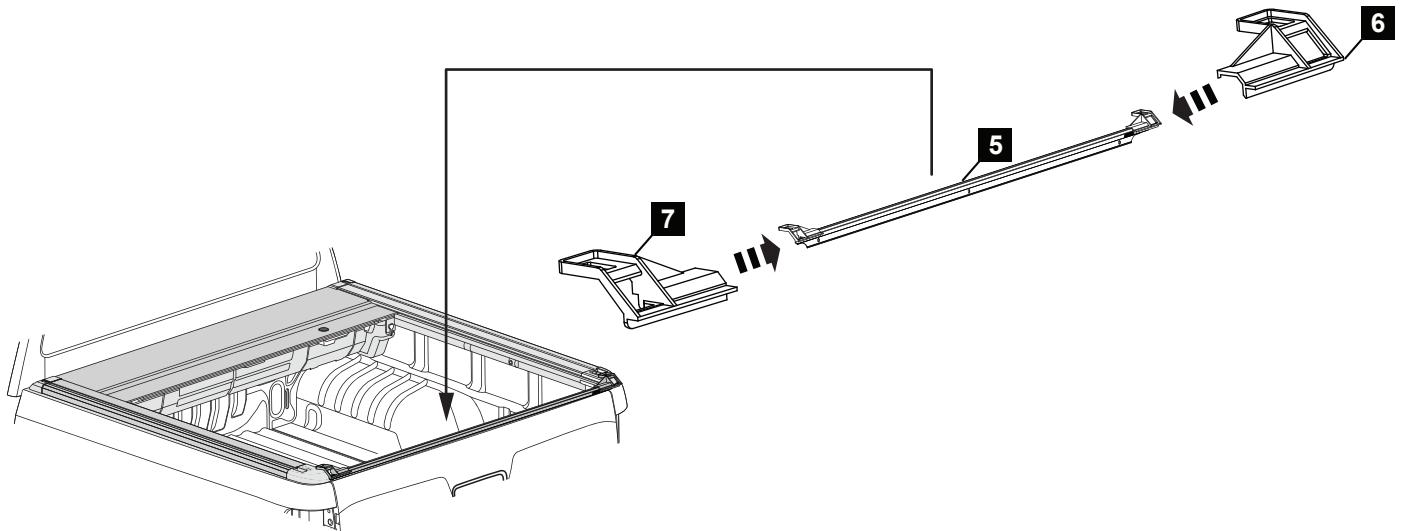

**5** Open the tailgate. Assemble jigs to the tailgate rail, position on rear corners of the cover. Gently close tailgate.

REAR TOP VIEW

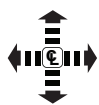

C/L

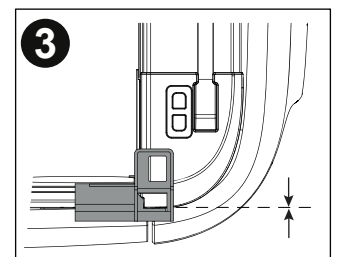
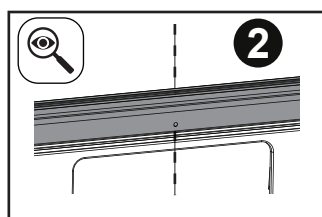
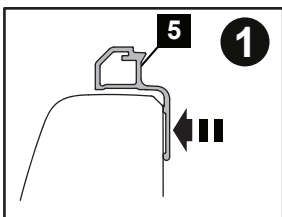

**6** Press tailgate rail firmly against the tailgate. Check and adjust side to side by aligning the centre slot of the tailgate rail with pre marked centre line. Check front to back position of cover on tub using jigs as a guide.

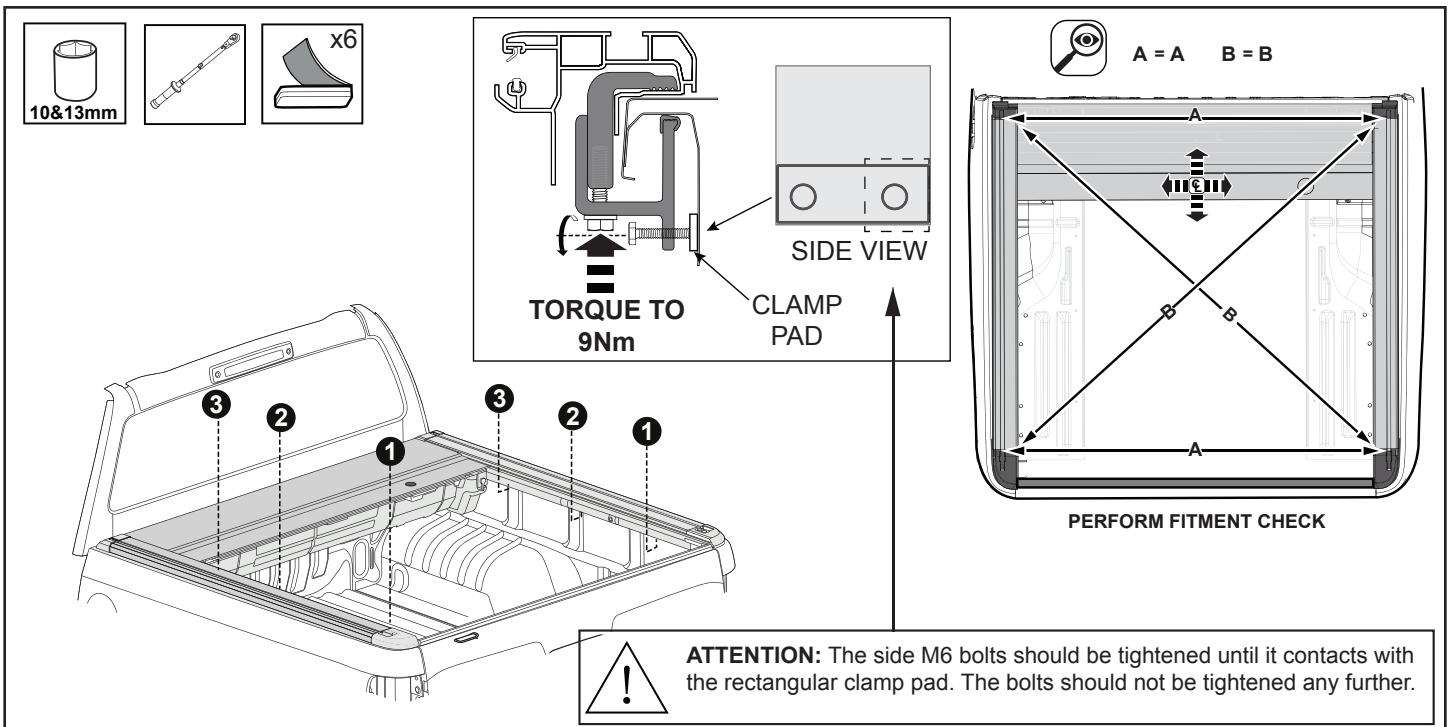

- 7** Torque (9Nm) the rear set of cover clamp bolts, ensuring cover does not move after tightening. Perform diagonal fitment check (bolts may need loosening for adjustment). At this stage the clamp bolts should be tightened from tailgate to the cab to 9Nm.

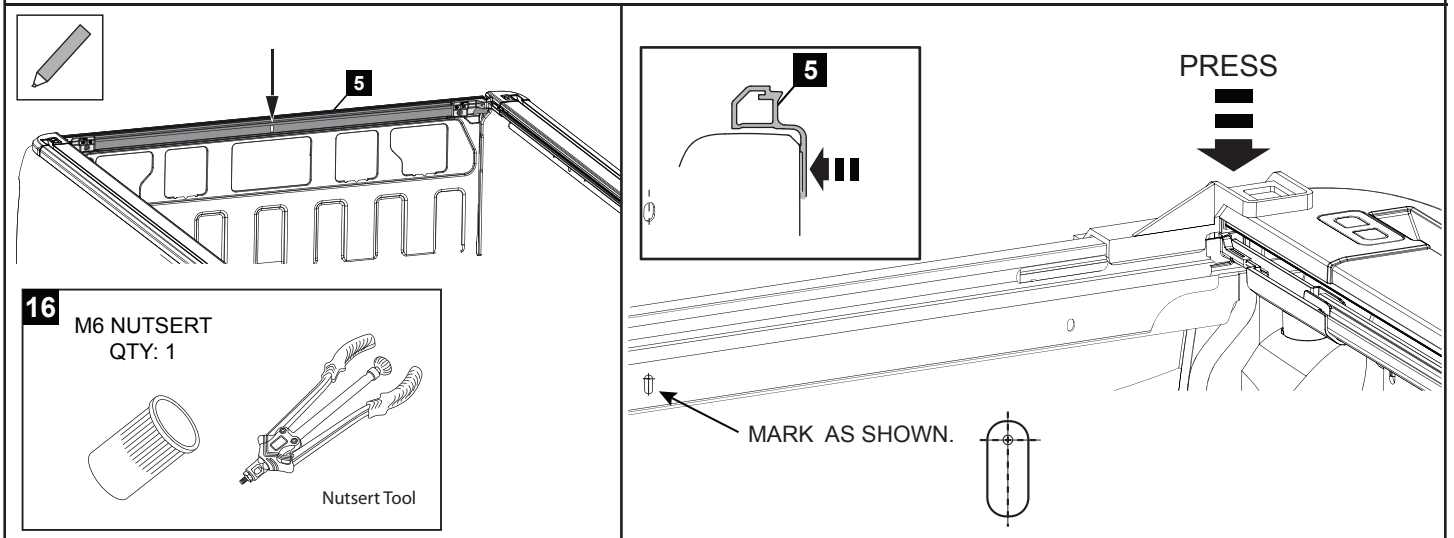

- 8** Ensure the Tailgate Rail (5) is pushed down and flush with the tailgate. Mark and centre punch the centre slot as shown. Remove tailgate rail and jigs. Drill marked location with 9mm Step Drill. Apply rust inhibitor to the hole in the tailgate. Using Nutsert tool fit 1 Nutserts to the tailgate.

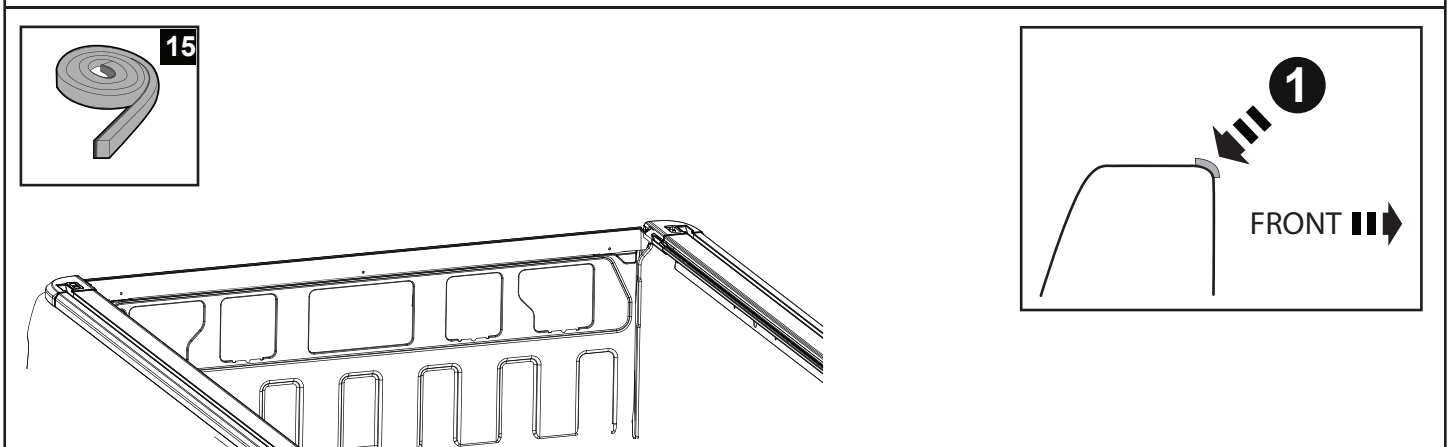

- 9** Clean tailgate with isopropyl alcohol (50/50), apply primer and let dry. Apply foam tape (15) to the tailgate inside top edge as shown in detail.

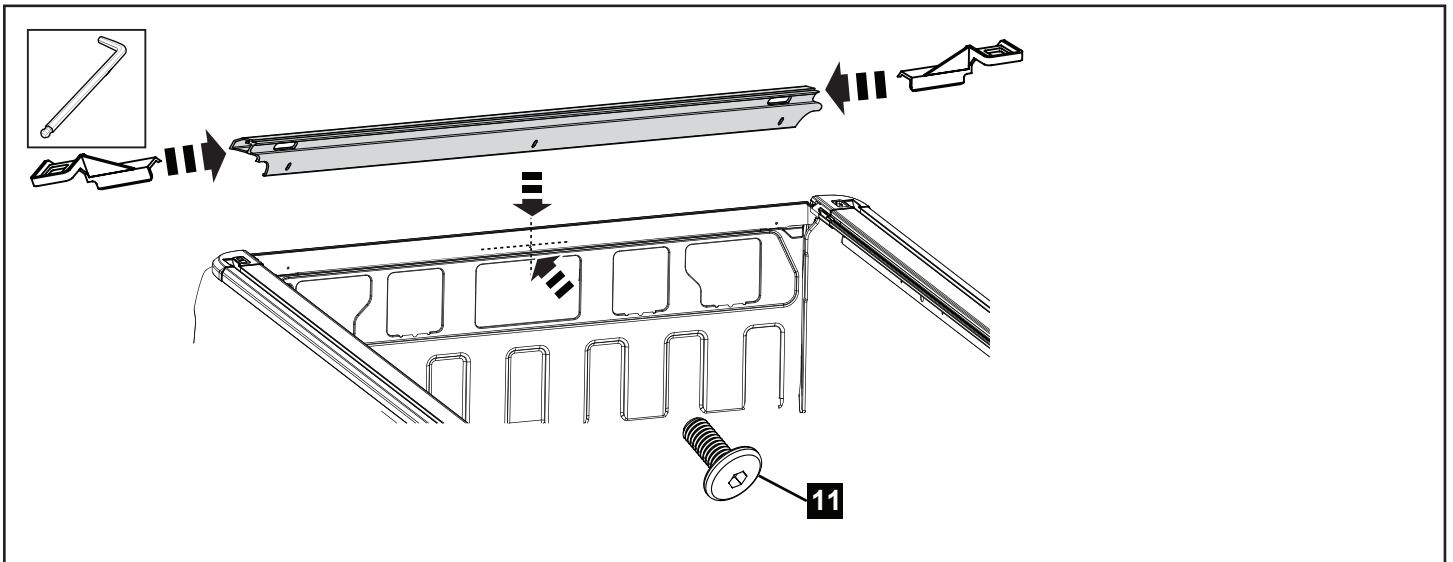

**10** Refit the tailgate rail with the jigs to the tailgate. Push down hard in the centre above the bolt fixing onto the tailgate rail and secure with the centre bolt as shown. Torque to 5.5Nm. Remove the jigs.

**1**

**2**

**11** Locate the Clutch Disengagement Lever on the RH side of the cover and push the Clutch inward to disengage the motor. Pull the cover rearward to check it is rolling freely and the alignment is 0.5mm above the tailgate rail as shown in detail. **NOTE: At this stage tape may need to be applied to the tailgate rail in order to lift the tailgate rail to the 0.5mm level as required.**

**16** M6 NUTSERT  
QTY: 2

Nutsert Tool

**12** Mark the two outside slot holes. Remove the tailgate rail. Centre punch and drill the 2 marked slot positions with 9mm Step Drill. Apply rust inhibitor to the holes in the tailgate. Using Nutsert tool fit 2 Nutserts to the tailgate.



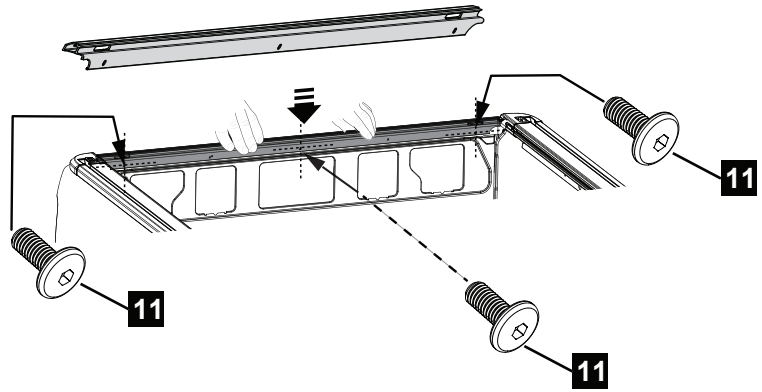
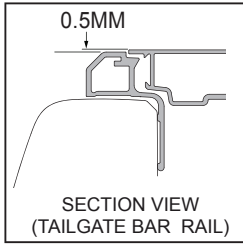
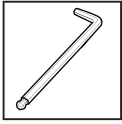

**13** Fit tailgate rail, push down to previous position and tighten with 3 M6 screws (11). Check 0.5mm alignment prior to torquing the screws to 5.5Nm.

**FIT FRONT DRAIN TUBES TO THE CANISTER**

**FIT REAR DRAIN TUBES TO SIDE RAILS**

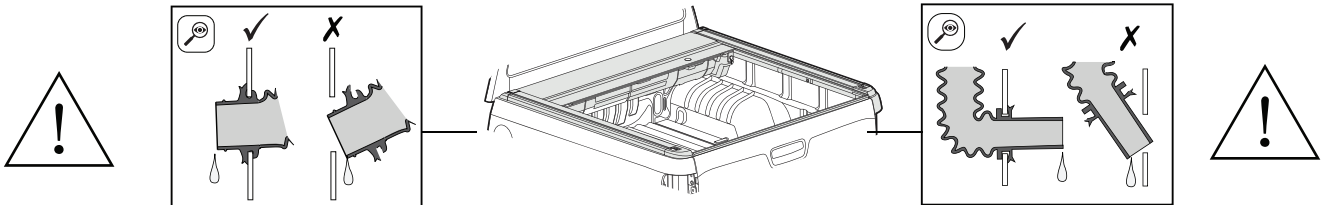
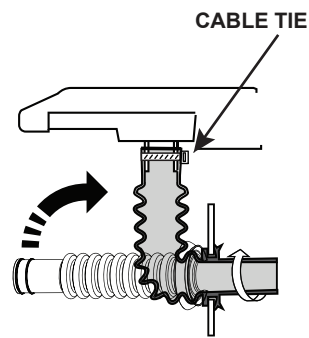
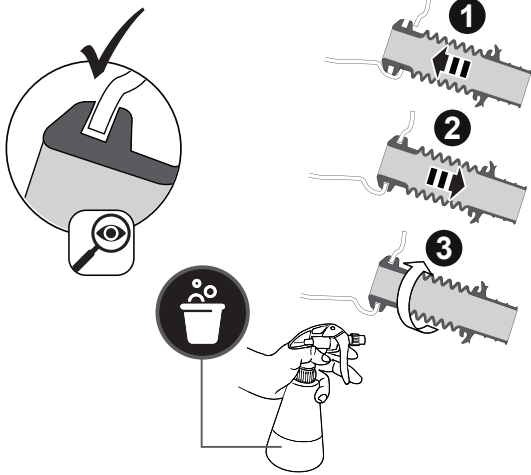

**14** Connect the front drain tubes (13) to the canister cover. Connect rear (14) drain tubes to the vehicle tub, making sure that both tubes engage over the wall of the tub. Leakage will occur if they are not properly installed.

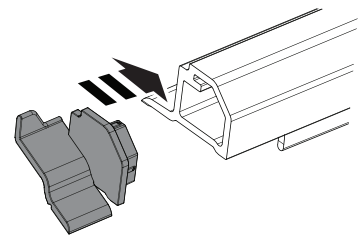
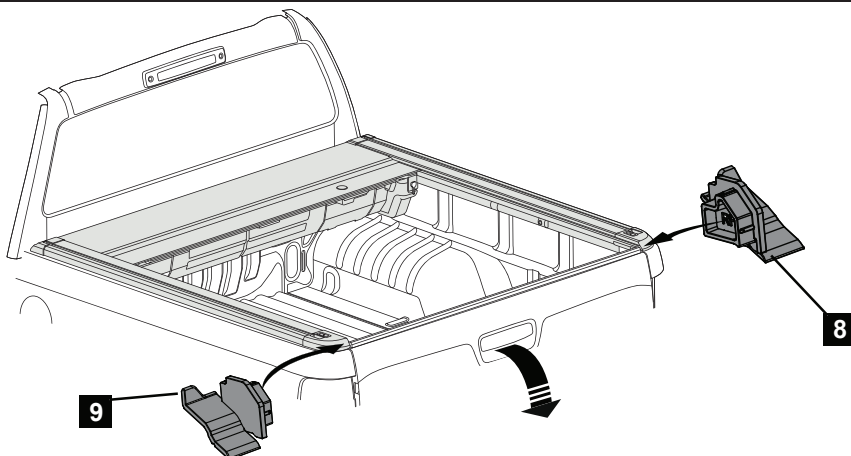

LHS SHOWN RHS IS A MIRROR IMAGE

**15** Open the tailgate and install the LHS (9) and RHS (8) Wiper Seals into the Tailgate Rail (3).

## RECOMMENDATION: SILICONE LUBRICATION TO THE SPIRALS & SIDE RAILS

1. Open the tailgate (EGR RollTrac is in open position).  
Using Silicone Spray (ONLY) spray onto both side rails.
2. Open both inspection covers.
3. Close the EGR RollTrac manually. NOTE: The motor clutch must be disengaged.
4. Using Silicone Spray (ONLY) spray onto the spirals on both sides of the canister.
5. Open EGR RollTrac manually.
6. Close and secure the inspection covers.

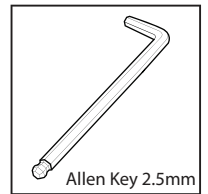

1

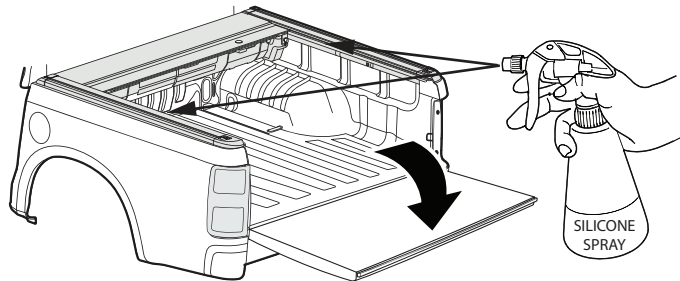

2

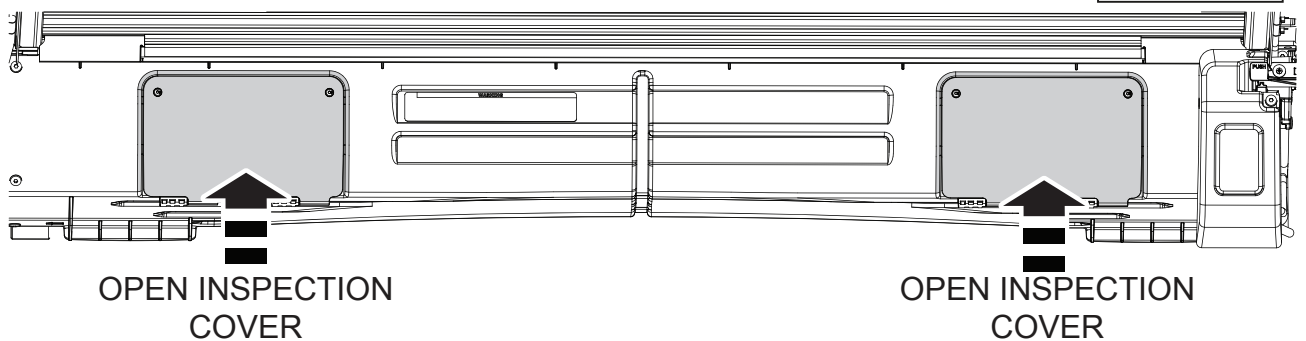

3

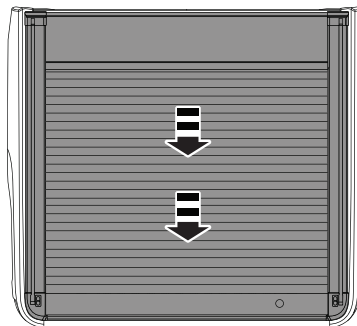
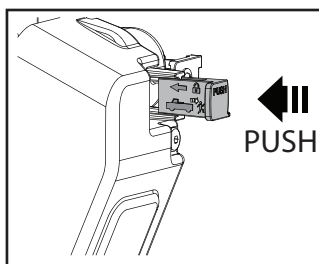

4

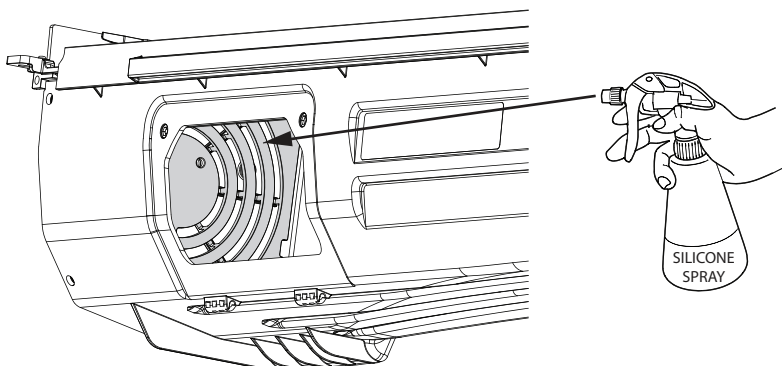

5

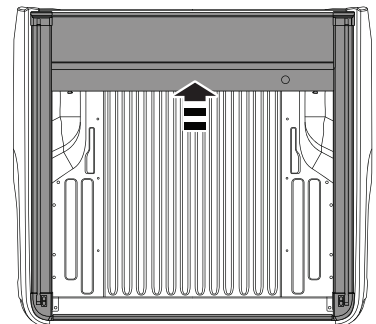

6

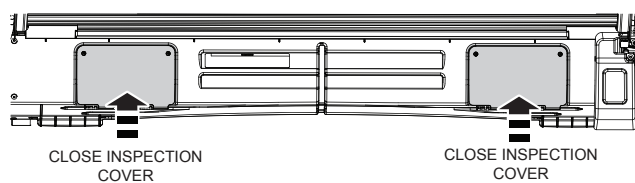

1. Insert fuse to EGR RollTrac harness.
2. Make sure the tailgate is open.
3. Engage motor, pull out lever (clutch).
4. Make sure the vehicle is unlocked and driver door open.
5. Press both buttons and hold for 10 sec. until light illuminates.



**WARNING:** Keep obstructions clear of cover during calibration mode.

**IMPORTANT:** Do not leave the Rolltrac keys inside the tub.

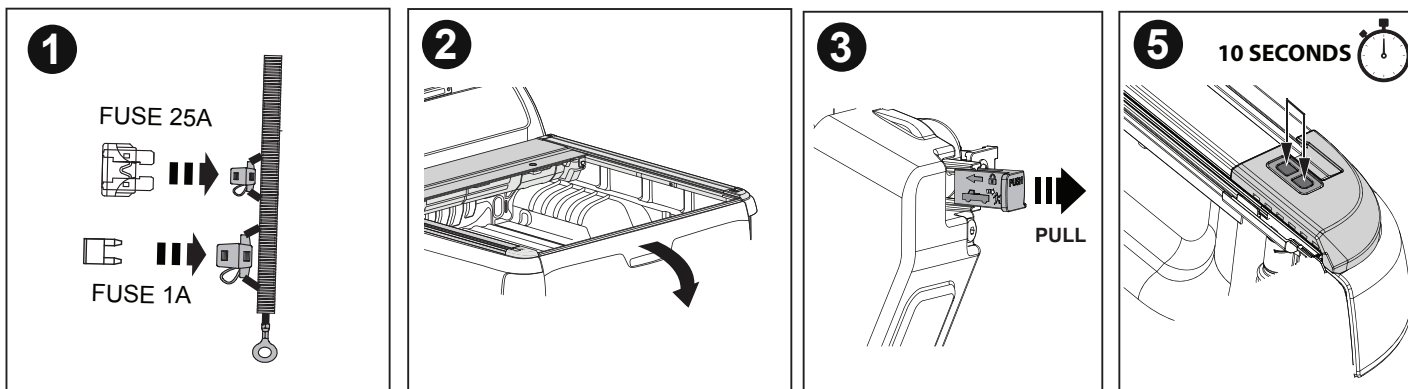

- Cover will open and close twice automatically.
- The EGR RollTrac internal LED light will pulse slowly during calibration and stop pulsing when calibration is complete.

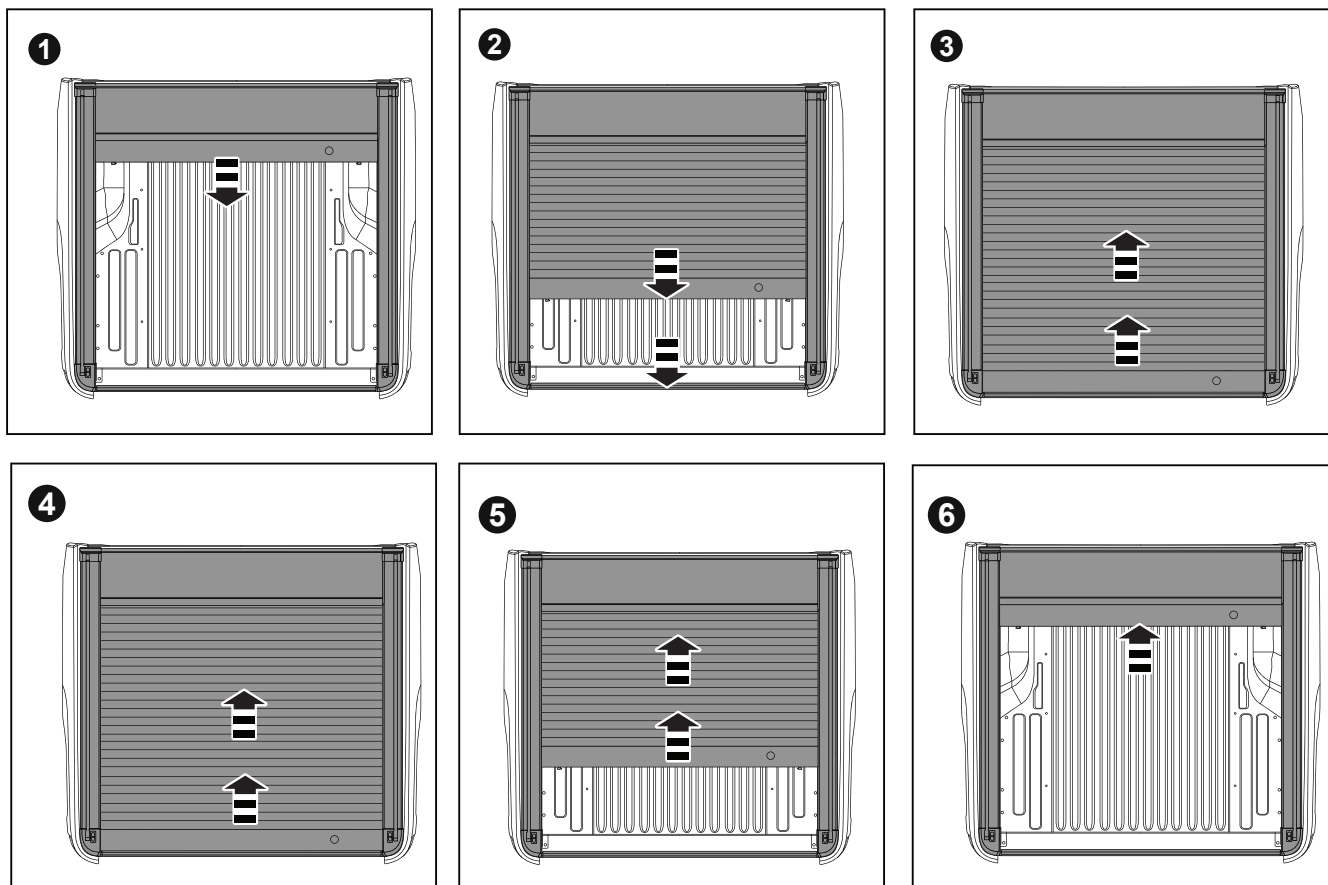
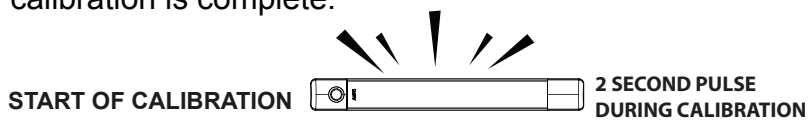

## OPENING AND CLOSING PROCEDURE

### Electric Opening Procedure:

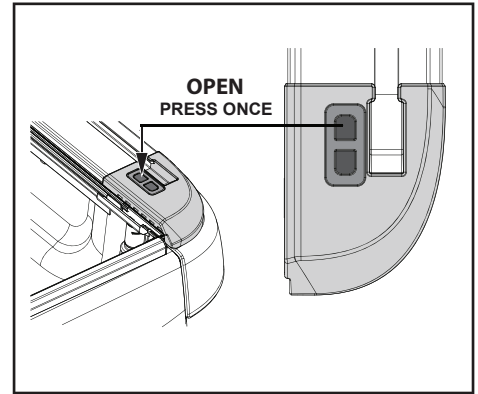
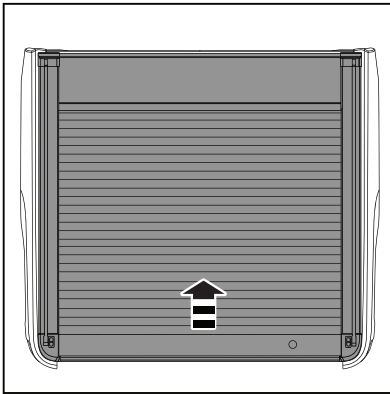

1. Press the "UNLOCK" button on the car remote.
2. Press the front button on the EGR RollTrac side rail as shown.

### Electric Closing Procedure:

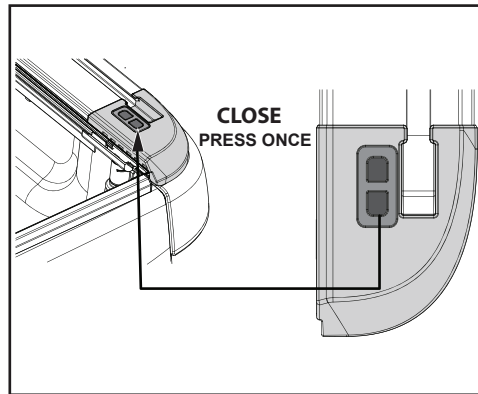
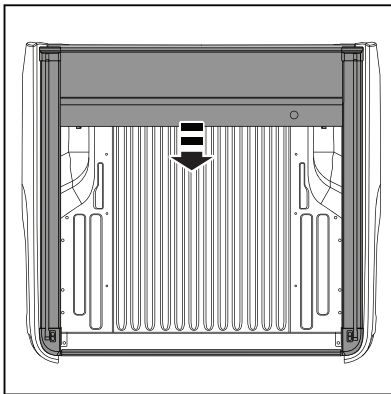

1. Press the rear button on the EGR RollTrac side rail as shown.
2. Press the "LOCK" button on the car remote.

NOTE: EGR RollTrac should open and close smoothly. If cover does not lock or open correctly, please refer to the trouble shooting section in the Owners Manual. If the EGR RollTrac closing is slow, clean the siderails and ensure that no dirt or debris is inside the drive rail.

### Manual Opening and Closing Procedure:

Locate the Clutch Disengagement Lever on the RH side of the cover and push the Clutch inward to disengage the motor. Pull the cover rearward or forward as required. Before driving vehicle ensure you re-engage the clutch.

**IMPORTANT:** If clutch was disengaged, calibration procedure needs to be re-run prior to electric operation.

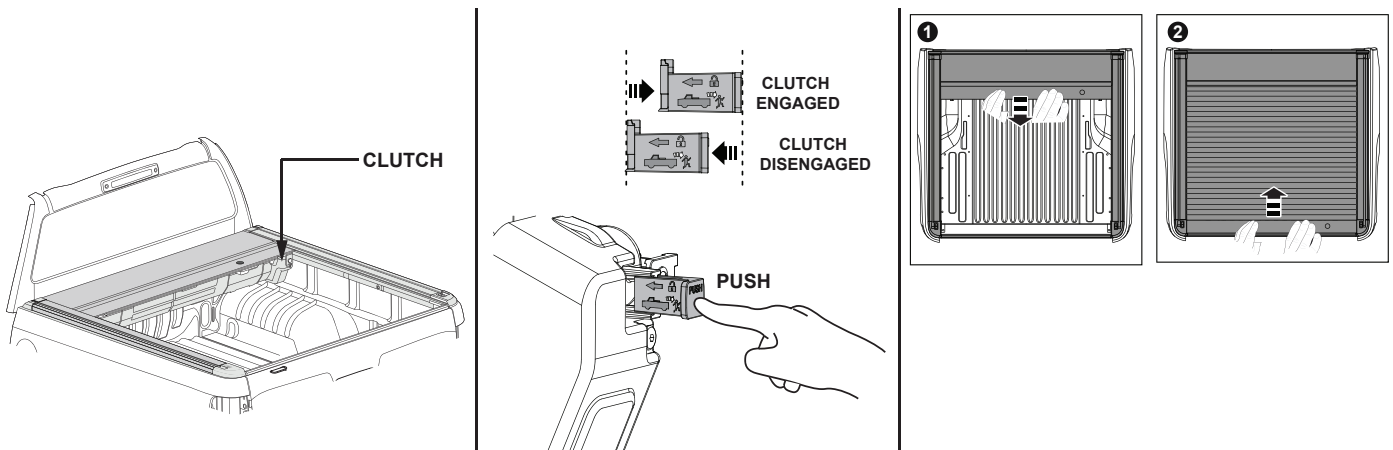

## LOCKING PROCEDURE

### Manual locking / unlocking using key:

1. Ensure cover is fully closed.
2. Open the rubber cap covering the lock and using the provided key turn RIGHT to lock and LEFT to unlock the cover.
3. Check lock engagement by opening the tailgate, if lock does not engage recheck cover installation

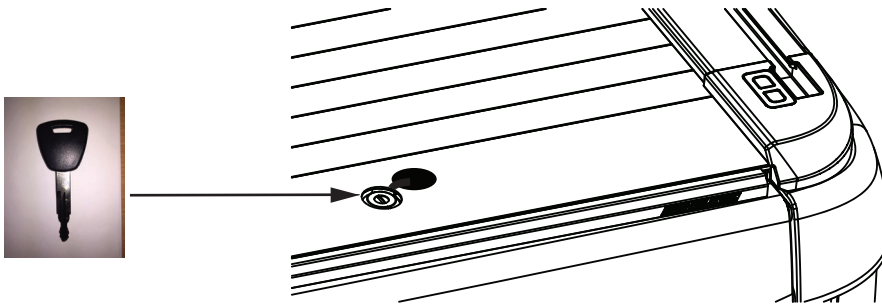

### Electric locking / unlocking using key:

1. Ensure cover is fully closed.
2. Lock or unlock the cover by using button on the key remote.
3. Check lock engagement by opening the tailgate, if lock does not engage recheck cover installation

**NOTE:** If vehicle is locked, buttons are deactivated and cover will not open/close.

Lock latches will not activate until cover is in fully closed position.

Ensure to return tailgate to fully closed position prior to lock/unlock.

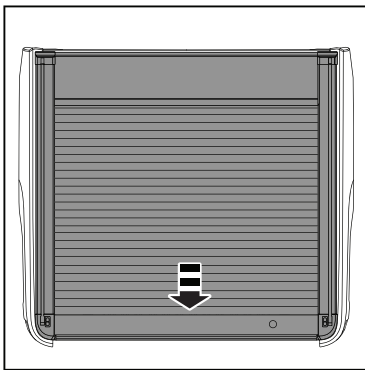

### Emergency Opening:

1. The EGR RollTrac has an internal manual unlocking handle.
2. Test the operation by twisting the handle as indicated by the arrows and ensure latches move.

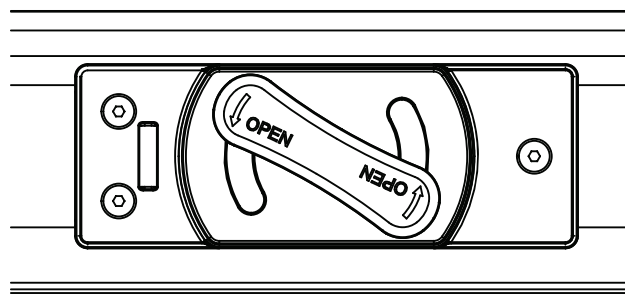

### FINAL NOTES:

Dispose of all packaging and waste according to local regulations.

Retain your Owners Manual, Fitting Instructions and fitting jigs for future reference.

Refer to Owners Manual for operation, warranty, service and product care guidelines.

Complete the installation check list in Owners Manual and store keys safely.

Clean the EGR RollTrac using multi purpose cleaner to remove any residue from packaging and installation.